

The Science Teachers Bulletin

*Promoting Excellence
in Science Education*



Volume 83, Number 2
Spring/Summer 2020



STANYS EXECUTIVE BOARD 2020-2021

President

Dominick Fantacone

Southern STANYS Section

president@stanys.org

President Elect

Shelly Hinchliffe

Northwestern STANYS Section

presidentelect@stanys.org

Vice President

Matt Christiansen

Suffolk STANYS Section

vicepresident@stanys.org

Secretary

Karin Cyganovich

Northwestern STANYS Section

secretary@stanys.org

Treasurer

Sandra George

Western STANYS Section

treasurer@stanys.org

Past-President

Lisa Brosnick

Southwestern STANYS Section

pastpresident@stanys.org

The Science Teachers Bulletin

Volume 83, Number 2

Spring/Summer 2020

Official Publication of the
**Science Teachers Association of
New York State, Inc.**

PO Box 2121

Liverpool, NY 13089

(516) 783-5432

www.stanys.org

A State Chapter of the National Science Teachers Association and a member of the New York State Council of Education Associations



Editor:

Aaron D. Isabelle, Ph.D.

State University of New York at New Paltz
School of Education

800 Hawk Drive

New Paltz, NY 12561

bulletineditor@stanys.org

Assistant Editors:

Dan MacIsaac, Ph.D.

danmacisaac@gmail.com

Dominique Preston

nikkipreston19@gmail.com

The Science Teachers Bulletin

©2020 STANYS

Published twice a year

All rights reserved.

Permission to duplicate any part of this journal may be requested in writing from the editor.

Opinions expressed herein are those of the authors and may not reflect STANYS policy.



Don't forget to submit **YOUR** article for the next issue of

**The Science Teachers
Bulletin**

See guidelines for submission
on the back cover.

Contents

CRISPR-Cas Genome Editing and the High School Classroom	6
Dan Williams	
Using a Modified Understanding by Design (UbD) Template to Unpack the Intermediate <i>New York State P-12 Science Learning Standards</i>.....	19
Carol-Ann Winans	
Instructional Insights for Using Water Circuit Analogies for Learning Introductory Circuits.....	31
Kevin Gee	
Building a Model of Optical Diffraction and Interference for High School Students Using Multiple Inquiry-based Physics Activities	52
Quinn Thomson	
The Buffalo State College Campus Geology Display: An Outdoor Geology Classroom	75
Gary S. Solar	

CRISPR-Cas Genome Editing and the High School Classroom

Dan Williams

Abstract

Almost every day, CRISPR-Cas systems make the news—from their ability to rapidly diagnose a disease like COVID-19, to reducing cholesterol as a genetic treatment for heart disease. This technology is already changing the world, but are our classrooms changing along with it? Is CRISPR-Cas genome editing ever mentioned or discussed in Living Environment, AP Biology, or Science Research classes? Are our students exposed to the power of CRISPR and associated ethical issues? This technology is new—only a few years old—and might at first glance be out of reach for the high school biology teacher. It is my hope that this article changes that. CRISPR-Cas genome editing is not only accessible to the high school classroom; it is essential that it is covered in order to empower student scientists with the critical thinking skills needed to tackle the complex issues that a genome-edited world faces.

Introduction

On Saturday June 27, 2020 the headline in the New York Times read, “A Cure for Heart Disease?” The article, based on the announcement from Verve Therapeutics, stated in a published study that CRISPR-Cas base-edited monkeys and mice had significantly lower cholesterol levels and therefore a lower risk of heart attacks (See Figure 1). The gene of interest in this study, *PCSK9*, in theory could potentially provide an 88% reduction in a person’s lifetime risk of coronary artery disease once edited. This could be a major leap forward in human health, brought about by the relatively new technology of CRISPR-Cas genome editing.

Clustered Regularly Interspaced Short Palindromic Repeats, also known as CRISPR, paired with an associated protein, Cas, is what makes up the CRISPR-Cas system of genome editing. As often with biology, this technology is ripe with confusing acronyms and techno-speak that might scare off high school teachers who are not looking to go back to school for molecular biology. However, it has been my experience and hope that through some simple modeling and the accessibility of online tools, CRISPR becomes a valuable teaching tool to use throughout biology curriculum. It is essential that CRISPR is covered in our classrooms to prepare future scientists with needed skills for 21st century biology and enable the critical thinking needed to tackle the complex issues that a genome-edited world now faces.



Figure 1.
<https://www.nytimes.com/2020/06/27/health/heart-disease-gene-editing.html#click=https://t.co/xwmekswwah>

<https://www.genengnews.com/news/mammoth-biosciences-licenses-2-uc-patents-for-crispr-based-diagnostic-platform/> (This platform has been adapted for COVID-19 testing awaiting approval from the FDA)

The study of CRISPR in the classroom also provides multiple ways to implement the *New York State P-12 Science Learning Standards* (NYSLSS) and the *Next Generation Science Standards* (NGSS). Through this expansive topic, students can increase engagement with natural scientific phenomenon, participate in engineering practices and apply crosscutting concepts. In this essay, I offer both a set of broad interdisciplinary concepts and practical activities, starting with a view of history and ethical challenges to cutting edge science.

History

CRISPR sequences in the DNA of bacteria were discovered by Yoshizumi Ishino of Osaka University in 1987. In 2007, scientists like Rodolphe Barrangou of Danisco USA, a yogurt company, suggested that CRISPR sequences and the action of Cas (CRISPR Associated) proteins function as an adaptive immune system for the bacteria against phages, viruses that kill bacteria. In 2012, Jennifer Doudna and Emmanuelle Charpentier demonstrated that this bacterial “immune system” can be fine-tuned for efficiency and “programmed” to target mostly any gene

of choice, opening the door for potential CRISPR-Cas genome editing. This is what CRISPR is known for today—genome editing and its power to change the world.

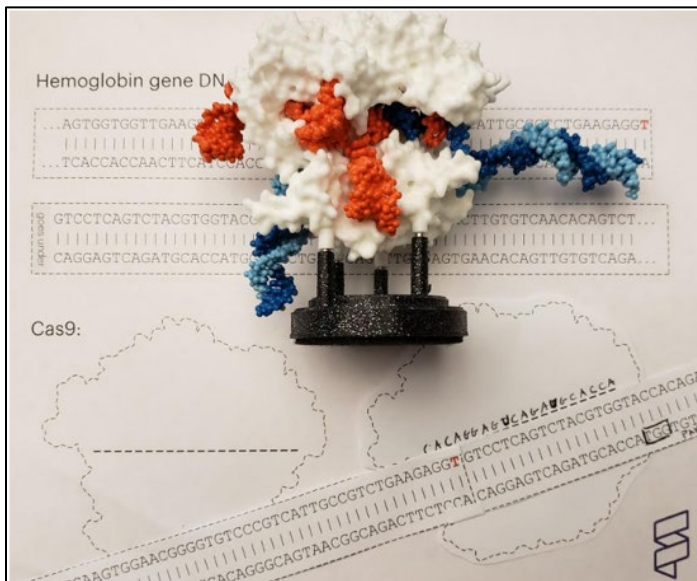

Figure 2. Model of CRISPR/Cas9 from 3D Molecular Designs

This little history lesson is part of the “wonder” of CRISPR-Cas. Think about the diversity in the previous paragraph: a DNA scientist examining a gene sequence, a yogurt scientist looking to keep vital strains of bacteria safe from phages, and a protein scientist manipulating that system in a novel way. Who would think their research could be related to one another? This leads to a few important lessons for our science students. First, no matter how obscure one’s research seems today, it might change the world and is therefore valuable. Secondly, discoveries do not happen magically, such as bumping one’s head and seeing the “flux capacitor”—they are built upon previous work.

In her book, *A Crack in Creation*, Jennifer Doudna states that when she was approached by Emmanuelle Charpentier about an interesting bacterial system, she had to research to learn exactly what Dr. Charpentier was proposing. Students today often think that they will come up with a great idea and in one school year, will conduct a project that will win the Nobel Prize. What is even worse is that in our research class culture, we encourage this false narrative. Research is journey of discovery, not a race for a prize. Examination of the historical experiments that helped us get to where we are today is an important reminder of that.

Another important part of this history lesson is to remind teachers and students of coding and bioinformatics. If Yoshizumi Ishino did not look for unknown or odd sequences in and around the gene he was studying, there is no telling when these repeats would have been discovered. Who knows what unknown or odd sequences lie in wait in genomes yet to be discovered now? Luckily, it is fairly easy to expose students to a simple coding exercise: download a genome FASTA and write a code to search for the longest repeated string or the string repeated most often. We may not be currently teaching coding in our classrooms or science labs, but the history of CRISPR-Cas advancements suggests that we should begin sooner rather than later to give our students the opportunity to discover something big (See Figure 3).

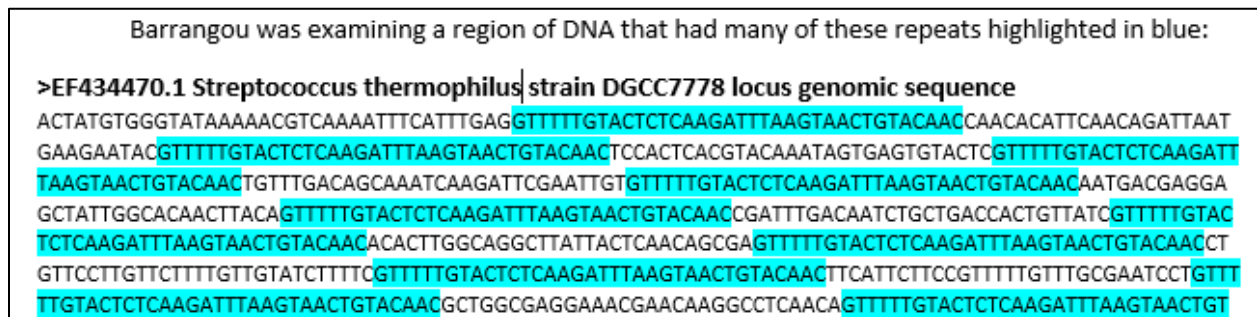

Figure 3. CRISPR repeats studied by Barrangou are in blue; the viral interrupting sequences are not highlighted (<https://www.ncbi.nlm.nih.gov/>)

Likewise, how much are we teaching bioinformatics? Barrangou’s discovery that CRISPR-Cas was an adaptive immunity is an exercise in bioinformatics. The spacer regions of the CRISPR locus are viral DNA sequences; easy enough to discover with BLAST searches. Today, scientists around the world are finding new applications for CRISPR-Cas and discovering new varieties of the system by simply examining BLAST hits and phylogenetic analysis. Often, our students think of phylogeny as simply an exam question rather than something that leads to new discoveries every day. Coding and bioinformatics are open-ended discovery research—a journey into the unknown, not a “eureka!” moment. Our students can be doing work like this, and it is free as long as one has access to a computer. Some suggested activities are listed at the end of this article.

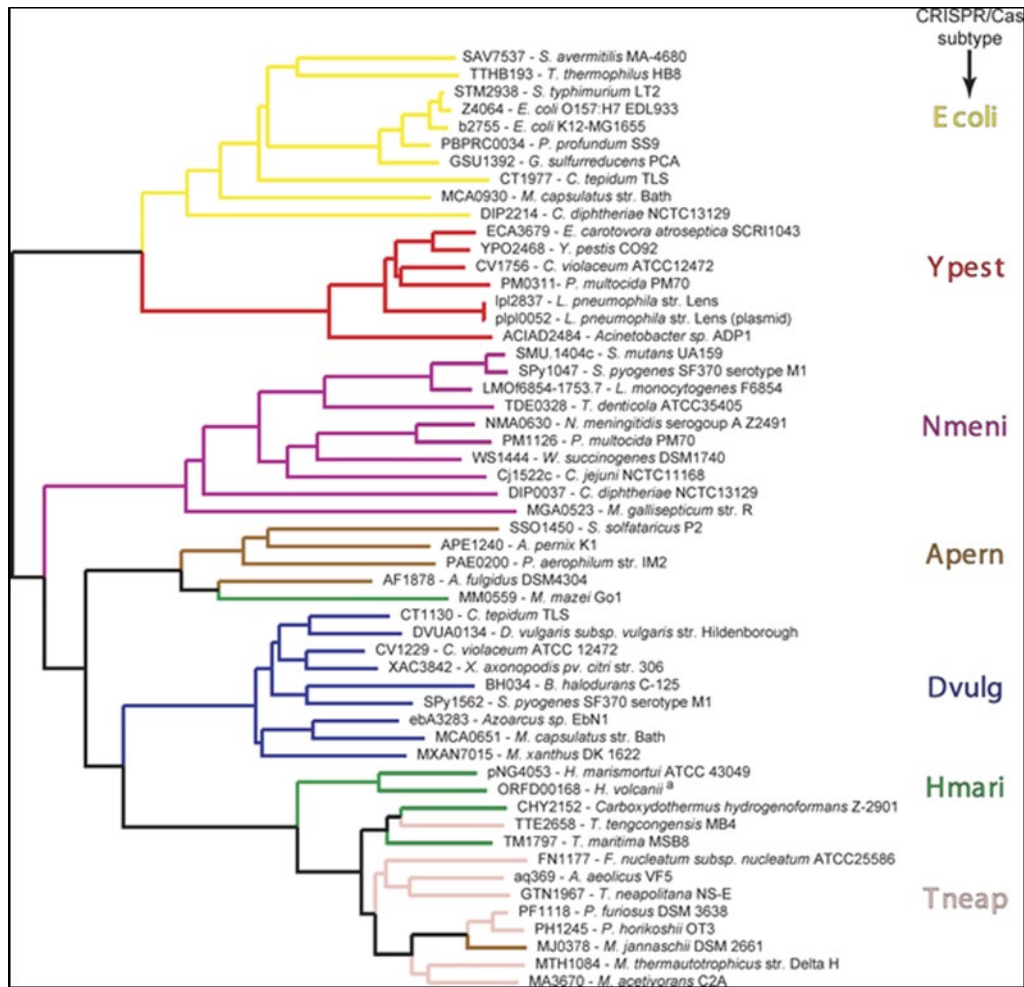

Figure 4. Different Cas subtypes identified by phylogenetic analysis. Haft, Daniel H., et al. A Guild of 45 CRISPR-Associated (Cas) Protein Families and Multiple CRISPR/Cas Subtypes Exists in Prokaryotic Genomes

Classroom Resources

The CRISPR-Cas system is programmable genetic engineering and surprisingly easy to model in the high school classroom. It is truly the “wonder enzyme system” that is simultaneously simple and complex. Students can research diseases they wish to cure or traits they want to change and design, and they can test a CRISPR-Cas system to investigate if it is possible. It sounds too simple and too good to be true, but you might be surprised at what can actually be done.

In order to complete such a study, students can do the following:

1. Find a gene of interest using online tools such as the National Center for Biotechnology Information (<https://www.ncbi.nlm.nih.gov/>)

2. Once a gene has been identified, discover if it has a CRISPR-Cas locus (<https://chopchop.cbu.uib.no/>).
3. Verify off-target hits and simulate if their target was correct with in silico PCR (<https://genome.ucsc.edu/>).
4. Test any hypothesis they want to see if a CRISPR experiment is possible. Even better, if your school has the ability, order their designed programmed CRISPR-Cas system from companies like AddGene (<https://www.addgene.org/>) and test it in a wet lab situation.



Figure 5. CRISPR Logo from Integrated DNA

Last year at Cold Spring Harbor’s scientific meeting “Genome Engineering: CRISPR Frontiers,” I learned that scientists are testing the viability of their CRISPR designs by simply ordering the system from a company like AddGene by cutting a plasmid that contains the target sequence. If the plasmid is cut, the designed CRISPR-Cas system works. It is easy enough to cut a plasmid in a classroom and run it on a gel electrophoresis—classrooms have been doing that for years. Ultimately, whether you want students to design a virtual experiment or test a real one, CRISPR-Cas can be done in the high school laboratory.

Ethical Conversations

In designing a CRISPR-Cas experimental system, students should start to realize how it is not foolproof; things can go wrong. What unforeseen challenges or controversies could be lurking? Surely, simply cutting a plasmid is different from cutting a patient’s DNA. We know so little about our own genomes—what risks would be acceptable? What threshold is considered

“too much?” Where do we draw the line of risk between a patient who is sick or dying compared to enhancing genes for other purposes?

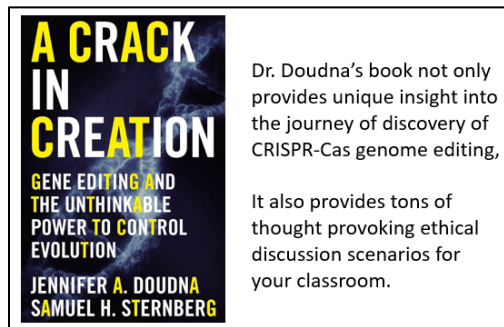

Figure 6. *A Crack in Creation* by Jennifer Doudna

The ethics of CRISPR-Cas make our current classroom discussions of genetically modified organisms look quaint. The promise of CRISPR-Cas is that it can make genome editing much faster, cheaper and easier than ever before. In our classrooms, we should be having the discussions of the differences between therapeutic gene editing, preventative gene editing, and gene insertion. To clarify, therapeutic gene editing fixes a disease with a known wild-type variant, such as sickle cell anemia being fixed by replacing the defective hemoglobin with a normal one. Preventative gene editing involves proactively altering a person's genes who has a ticking time bomb within their DNA (e.g. BRACA –breast cancer). Finally, gene insertion includes adding novel sections to an organism's genome, such as making a pest-resistant tomato or as some would fantasize, unicorns and other mythical creatures. Of course, there are many pros and cons to discuss within each of these instances. Similar to the discussion of genetically modified organisms, there are no easy answers. However, our students must learn how to examine each issue with critical thinking, using evidence-based justifications to form their opinions.

At this point, you may be thinking to yourself that tackling the concept of CRISPR-Cas with students is overwhelming. Remember, what makes CRISPR-Cas so wonderful is that it provides so many potential solutions and discussions. It is truly the wonder enzyme system that has so many applications in the classroom. Students can model, design experiments, and justify claims with evidence all from CRISPR-Cas.

Most importantly, remember that as a teacher, you do not have to reinvent the wheel; there are many tutorials and educational material available. If you are looking for a great place to start, the Innovative Genomics Institute (<https://innovativegenomics.org/>), founded by Dr. Doudna herself, has incredible resources ready for use in the classroom and they will respond to your inquiries with answers.

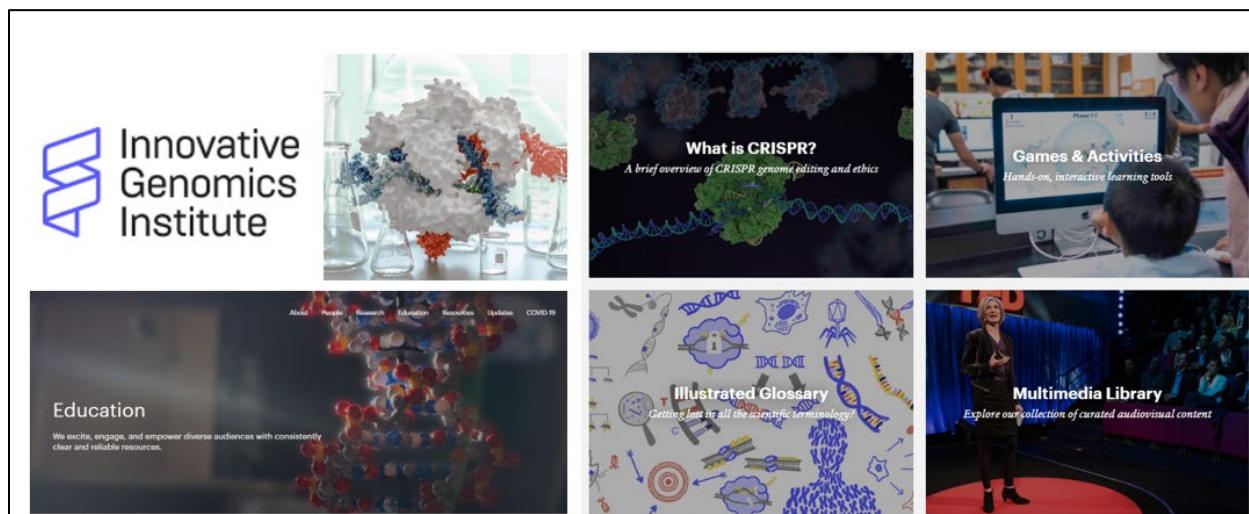

Figure 6. The Innovative Genomics Institute has great resources:
<https://innovativegenomics.org/education/>

Activities/Labs

I have written several activities that I am currently trying with my students and would be happy to share editable copies with anyone who asks. To try it in your own classroom, send me an email at dan.williams@shlterisland.k12.ny.us. The activities include the following, in order from introductory activities to more advanced:

- **Discovering CRISPR –An Interactive Science Mystery**
An Exploration into the History of CRISPR’s Discoveries. Can your students discover CRISPR-Cas and its function using bioinformatics? This includes the original papers, testable DNA sequences, and guiding questions. I hope to add an open-ended coding activity this summer. The activity is designed as a modeling activity; students model their claim and justify their model based on the evidence in the activity. CRISPR-Cas has many moving parts and, as typical of biology, way too much vocabulary. The modeling along with the bioinformatics will allow the students to identify the major players, what they do, and why they are important. You can add the real vocabulary as you go.

Multiple Sequence Alignment
 Clustal Omega is a free multiple sequence alignment program that uses seeded guide trees and HMM profile-profile techniques to generate alignments between three or more sequences. For the alignment of two sequences please instead use our pairwise sequence alignment tool.

Important note: This tool can align up to 4000 sequences or a maximum file size of 4 MB.

STEP 1: Enter your input sequences

Enter a paste of DNA

Make sure you paste your sequences correctly

Paste your sequences

STEP 2: Set your parameters

OUTPUT FORMAT: Clustal with character counts

The default settings will fulfil the needs of most users. [More options](#) (Click here if you want to view or change the default settings.)

STEP 3: Submit your job

Be notified by email (Tick this box if you want to be notified by email when the results are available)

Submit Press 'Submit' to run the alignment

Students follow prompts to see if they can 'discover' the biological functions of CRISPR-Cas systems in bacteria.

With each new program introduced, students can add it to their Bioinformatics toolbox -so when faced with a new phenomenon, they could look in their toolbox to find the right tools to explore the topic.

Your alignment will appear listed in the next window

Areas of sequence that are in complete alignment will have an * underneath

Tool -Clustal W <https://www.ebi.ac.uk/>

What the tool does: Clustal is a DNA or protein multiple seq that can also be used to create phylogenetic trees

Sample applications: Examine if sequences are the same or find patterns in conserved regions that indicate areas of important

Create a notecard of this tool and place it into you Bioinformatics Toolbox at the end of this activity

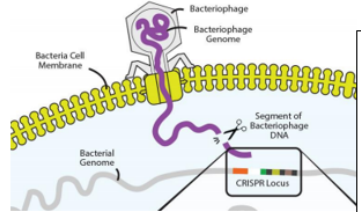

Students will make a claim based on the evidence of the activity. Then students will model how CRISPR-Cas works in bacteria.

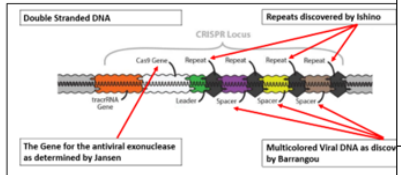

The modeling is designed to integrate separate discoveries into one cohesive story that was brought to light by decades of research.



Consistent color coded, shape based lock and key pieces enable students to model the steps of bacteria immunity. It is through modeling that the story comes together, here you can introduce the actual vocabulary if you wish.

- Modeling CRISPR-Cas Action with a Kit from 3D Molecular Designs**
 Hopefully, this kit will be available for purchase during fall 2020. Although I am helping develop their kit, I receive no financial compensation from them for sales or promotion. You can use my activity to help build/draw models on your own or have student design models. This activity helps students see and manipulate the nuclease sites, the PAM binding site, and how the guide RNA targets the correct DNA sequence. CRISPR-Cas is very vocabulary intensive, and this colorful manipulation activity helps put a physical structure with a function and a name. Students also have the ability to model Holliday

structure cross-over events that enable genome editing. I have even modeled simple base editing techniques (e.g., changing a single nucleotide) with this.

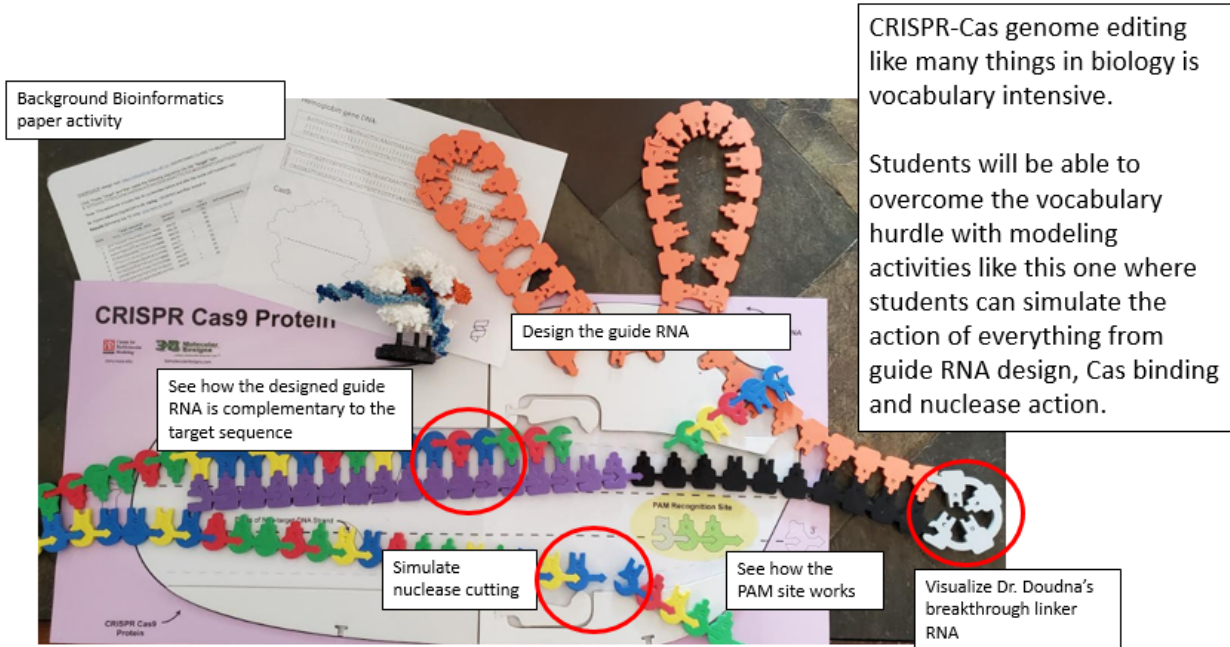

- **Design and Test a Virtual CRISPR-Cas Experiment**

A case study of designing a CRISPR-Cas knockout of PD-1, a hopeful target in cancer research. This is designed to take students step-by-step through what they would have to do to design a CRISPR-Cas experiment. Once the students know the steps, they can substitute any gene of interest to explore the possibilities. This helps students understand both the promise, limitations, and potential pitfalls of CRISPR-Cas experiments.

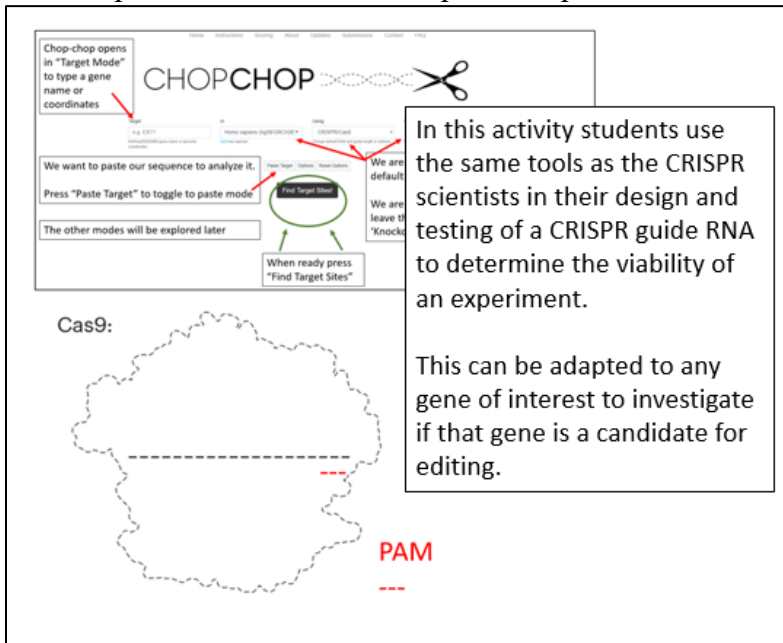



Tool –ChopChop [https://chopchop.cmu.edu/](https://chopchop.crispr.cmu.edu/)

What the tool does: ChopChop finds potential CRISPR-Cas9 target sites in a DNA sequence. The first step to determine if your gene of interest has any CRISPR-Cas9 target sites.

Sample applications: Paste in any gene sequence and get a list of potential CRISPR-Cas9 target sites. Can be modified for gene activation/repression and the use of different Cas proteins.



Create a notecard of this tool and place it into the end of this activity

With each new program introduced, students can add it to their Bioinformatics toolbox

-so when faced with a new phenomenon, they could look in their toolbox to find the right tools to explore the topic.

- **Ethics of CRISPR-Cas**

This is a list of current issues for students to research and discuss. It should be an open discussion with respect for differing views that can occur over multiple days. **This activity is not designed to be pro- or anti- anything.** Students must make a claim, most likely based off previous experience, and justify their claim with evidence. The goal of this activity is to engage students in critical thinking and evaluation of science-based evidence in the very complicated issues of genome editing.

RESPECT for PERSONS

- What would be respectful to the people (or other stakeholders) involved?
- How can we respect people and their right to make their own choices (autonomy)?

MAXIMIZE BENEFITS/ MINIMIZE HARMS

- How can we do the most good (beneficence) and the least harm (non-maleficence)?
- What kinds of harms and benefits might arise from different solutions?

ETHICAL QUESTION

JUSTICE

- What would be fair?
- How can we treat others equitably?
- How can we distribute resources so that each person gets what is due (justice)?

Students will be encouraged to think critically about the ethics of genome editing in a series of thought provoking case studies.

Students will need to back up their claims with facts not opinions realize these are not easy questions with simple easy to discern answers.

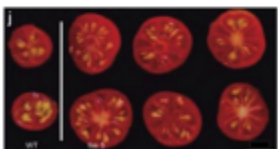

• Question 1: Should gene editing be used to restore disease and stress tolerance genes that were naturally available to tomatoes?

Conclusion

CRISPR-Cas genome editing is a technology that is only a few years old and is already changing the world. At first glance, it might appear to be out of reach for the high school biology teacher as it may feel too obscure and the technologically too difficult to teach to students. However, CRISPR-Cas genome editing is not only accessible to the high school classroom, it is essential that it is covered in order to empower student scientists with the critical thinking skills needed to tackle the complex issues that a genome edited world faces.

About the Author

Dan Williams is a Subject Area Representative (SAR) for STANYS Biology Science Teachers; a High School teacher at Shelter Island High School, Shelter Island New York; and a New York State Master Teacher of Biology. Dan teaches AP Biology, Biology (NYS Living Environment), Anatomy and Physiology, Marine Science and runs the Science Research program at Shelter Island High School. Dan earned his B.S. in Biology at St. Joseph's College in Patchogue, NY and Master of Arts in Teaching in Biology from SUNY Stony Brook, Stony Brook, NY. Dan is a cohort teacher at Milwaukee School of Engineering's Center for BioMolecular Modeling, a teacher fellow at Brookhaven National Laboratory's Office of Educational Programs, and Cold Spring Harbor Laboratory's DNA Learning Center. He is the advisor of an after school Science Club, a hands-on research and environmental sciences organization. He can be reached via email at dan.williams@shlterisland.k12.ny.us.

References

- Barrangou, R. (2007). CRISPR provides acquired resistance against viruses in prokaryotes. *Science*, 315(5819), 1709–1712. Retrieved from www.ncbi.nlm.nih.gov/pubmed/17379808/
- Doudna, J. A. & Sternberg S. H. (2018). *A Crack in creation: Gene editing and the unthinkable power to control evolution*. Boston, MA: Mariner Books.
- Haft D.H., Selengut J., Mongodin E.F. & Nelson K.E. (2005). A Guild of 45 CRISPR-associated (Cas) protein families and multiple CRISPR/Cas subtypes exist in prokaryotic genomes. *PLoS Computational Biology*, 1(6), 60. Retrieved from <https://doi.org/10.1371/journal.pcbi.0010060>
- Ishino, Y. (2018). History of CRISPR-Cas from encounter with a mysterious repeated sequence to genome editing technology. *Journal of Bacteriology*, 200(7), 2018, 00580-17. Retrieved from www.ncbi.nlm.nih.gov/pubmed/29358495
- Ishino, Y. (1987). Nucleotide sequence of the Iap Gene, responsible for alkaline phosphatase isozyme conversion in escherichia coli, and identification of the gene product. *Journal of Bacteriology*, 169(12), 5429–33. Retrieved from www.ncbi.nlm.nih.gov/pmc/articles/PMC213968/
- Jinek, M. (2012). A programmable dual-RNA-guided DNA endonuclease in adaptive bacterial immunity.” *Science*, 17(6096), 812-21.

Using a Modified Understanding by Design (UbD) Template to Unpack the Intermediate *New York State P-12 Science Learning Standards*

Carol-Ann Winans

Abstract

This manuscript addresses the use of a modified Understanding by Design (UbD) template to unpack the Intermediate *New York State P-12 Science Learning Standards* (NYSSLS). The goal is to successfully shift the sixth and seventh grade science curriculum at Wantagh Middle School, Long Island New York. UbD is an example of backward design – the practice of looking at the outcomes in order to design curriculum by identifying desired results, acceptable evidence towards demonstration of understanding, and learning experiences for classroom instruction. The UbD template uses three stages: Stage 1: Desired Results; Stage 2: Determine Acceptable Evidence; and Stage 3: Learning Experiences and Instruction. In this project, the Stage 1 template was modified to successfully isolate performance expectations (PEs), progressions, essential questions, disciplinary core ideas (DCIs), science and engineering practices (SEPs), and cross-cutting concepts (CCCs) to identify the desired outcomes of student learning for each unit. To help teachers identify these components within NYSSLS, the template was color coded. In Stage 2, performance tasks were created by identifying anchoring and assessment phenomena. In Stage 3, activities were selected to give numerous opportunities for students to draw inferences and uncover terminology. Students were provided opportunities to actively construct meaning (question), refine understanding (gather), and apply their learning to new situations (transfer).

Introduction

“In our current system, science education is measured by the ability of the students to memorize facts. As a result, our students focus on answers, not questions, through a competitive – not collaborative – environment. Students today need to learn to be comfortable in uncertainty and expand their perspective to be inclusive, not exclusive. The only human behavior that embraces uncertainty is play. Science is play with intention. If we can step out of our conditioned practice of designing for certain results, for a brief moment, we may be able to find a balance between design and play with intention.” – Dr. Beau Lotto, Neuroscientist specializing in human perception

To shift towards three-dimensional learning, the intermediate teachers at Wantagh Middle School wanted to create lessons that guided students towards understanding the DCIs and their ability to perform the PEs. In order to do this, units needed to be designed to provide opportunities to students to use the SEPs and CCCs as tools in this process. Lessons needed to include the opportunity for students to uncover information rather than receive it. Students

needed the opportunity to construct their understanding at different paces and achieve “Ah-ha! moments” as they developed. Teachers planned to use experiential learning to allow students to arrive at understandings and solidify a long-lasting foundation of the nature of science and key DCIs. This was a solid theory but posed a challenge once in practice.

After thorough research of a variety of programs, teachers selected the Stanford SCALE program as their starting point. This program focuses on developing curriculum that supports student sense-making through project-based learning. Using SCALE’s organization of the intermediate PEs, they established a baseline for a spiral curriculum unique to Wantagh Middle School, as seen in Table 1 and Table 2. It is important to note that some intermediate PEs have been moved to the 8th grade accelerated Living Environment curriculum.

Table 1: 6th Grade Science Performance Expectations

Physical Science	Earth and Space Science	Life Science
MS-PS1-1	MS-ESS2-1	MS-LS1-1
MS-PS1-3	MS-ESS2-2	MS-LS1-2
MS-PS1-7	MS-ESS3-1	MS-LS1-3
MS-PS1-4	MS-ESS3-5	MS-LS1-8
MS-PS1-8	MS-ESS3-3	MS-LS1-4
MS-PS3-3		MS-LS3-1
MS-PS3-4		MS-LS3-2
MS-PS3-5		

Table 2: 7th Grade Science Performance Expectations

Physical Science	Earth and Space Science	Life Science
MS-PS2-1	MS-ESS1-2	MS-LS4-1
MS-PS2-2	MS-ESS1-3	MS-LS1-6
MS-PS3-1	MS-ESS1-4	MS-LS1-7
MS-PS3-2	MS-ESS2-2	MS-LS2-1
MS-PS2-4	MS-ESS2-3	MS-LS2-3
MS-PS2-3	MS-ESS2-2	MS-LS2-4

MS-PS3-6 MS-PS4-1 MS-PS4-2 MS-PS4-3 MS-PS2-5 MS-PS1-2 MS-PS1-5		MS-LS2-2 MS-LS2-5
----------------------------------------------------------------------------------	--	----------------------

The teachers felt that in order to make this shift long-lasting, they needed to bring their own style and craft to the sequence and design. They needed a method of unit organization that would allow for ongoing reflection and modification.

“The act of teaching reaches its epitome of success after the lesson has been structured, after the content has been delivered, and after the classroom has been organized. The art of teaching, and its major successes, relate to ‘what happens next.’” – John Hattie, Educational Researcher

Procedure

To create a curriculum that inspired the growth of each teacher’s craft and evolution of unit structure, teachers turned to Understanding by Design (UbD). UbD is an educational planning approach advocated by Jay McTighe and Grant Wiggins in the book *Understanding by Design* (1998) that applies the practice of looking at outcomes in order to design curriculum by identifying desired results, acceptable evidence towards demonstration of understanding, and learning experiences for classroom instruction. Using the modified UbD template, teachers at Wantagh unpacked the standards, organized PEs by theme, and created memorable learning experiences for their students.

Part 1: Unpacking the Standards Using Stage 1 UbD

Stage 1 of UbD identified the desired results:

- What long-term transfer goals are targeted?
- What meanings should students make?
- What essential questions will students explore?
- What knowledge & skill will students acquire?

Unpacking the standards involved using a modified Stage 1 template of UbD. This aided the identification of PEs, progressions, essential questions, DCIs, SEPs, and CCCs in order to

identify the desired outcomes of student learning for each unit. To help teachers identify these components within NYSSLS, the template was color coded as seen below and in Table 3:

- **Orange** - DCI
- **Blue** - SEP
- **Green** - CCC

For each unit, the following artifacts were identified:

- Associated PEs or bundled PEs
- Progressions of each associated SEP and DCI
- Essential questions, which:
 - are open-ended with no simple “right answer”
 - can be investigated, argued, looked at from different points of view
 - encourage active “meaning making” by the learner about important ideas
 - raise other important questions
 - naturally arise in everyday life, and/or in “doing” the subject
 - constantly and appropriately recur; can fruitfully be asked and re-asked over time (Wiggins, 1998)
- PEs as major understandings
- DCI terminology as knowledge
- SEPs and CCCs as skills

Table 3: Completed Stage 1 modified UbD Template

	Unit: Forces and Interactions
	Types of Interactions - Gravitational Force
UbD Stage 1 – Establishing Goals and Desired Results	
Performance Expectation(s) /Bundles	
<p>MS-PS2-4. Construct and present arguments using evidence to support the claim that gravitational interactions are attractive and depend on the masses of interacting objects and the distance between them.</p> <p>MS-ESS1-2. Develop and use a model to describe the role of gravity in the motions within galaxies and the solar system.</p> <p>MS-ESS1-3. Analyze and interpret data to determine scale properties of objects in the solar system.</p>	
SEP Progression Appendix F	
<p>Engaging in Argument from Evidence Engaging in argument from evidence in 6–8 builds from K–5 experiences and progresses to constructing a convincing argument that supports or refutes claims for either explanations or solutions about the natural and designed world.</p> <ul style="list-style-type: none"> ● Construct and present oral and written arguments supported by empirical evidence and scientific reasoning to support or refute an explanation or a model for a phenomenon or a solution to a problem. (MS-PS2-4) 	

Developing and Using Models

Modeling in 6–8 builds on K–5 experiences and progresses to developing, using, and revising models to describe, test, and predict more abstract phenomena and design systems.

- Develop and use a model to describe phenomena. (MS-ESS1-2)

Analyzing and Interpreting Data

Analyzing data in 6–8 builds on K–5 experiences and progresses to extending quantitative analysis to investigations, distinguishing between correlation and causation, and basic statistical techniques of data and error analysis.

- Analyze and interpret data to determine similarities and differences in findings. (MSESS1-3)

DCI Progression Appendix E**PS2.B: Types of Interactions**

- Gravitational forces are always attractive. There is a gravitational force between any two masses, but it is very small except when one or both of the objects have large mass—e.g., Earth and the sun. (MSPS2-4)

ESS1.A: The Universe and Its Stars

- Earth and its solar system are part of the Milky Way galaxy, which is one of many galaxies in the universe. (MS-ESS1-2)

ESS1.B: Earth and the Solar System

- (NYSED) The solar system consists of the Sun and a collection of objects, including planets, their moons, comets, and asteroids that are held in orbit around the Sun by its gravitational pull on them. (MSESS1- 2),(MS-ESS1-3)
- The solar system appears to have formed from a disk of dust and gas, drawn together by gravity. (MSESS1-2)

What Essential Questions will be considered?	What understandings are desired
<p>How does gravity affect matter?</p>	<p>Construct and present arguments using evidence to support the claim that gravitational interactions are attractive and depend on the masses of interacting objects and the distance between them.</p> <p>Develop and use a model to describe the role of gravity in the motions within galaxies and the solar system.</p> <p>Analyze and interpret data to determine scale properties of objects in the solar system.</p> <p>How does the mass of an object affect its gravitational pull?</p> <p>What is the difference between mass and weight?</p> <p>What is the relationship between mass, weight and gravitational pull?</p>
What key knowledge and skills will students acquire as a result of this unit?	
<p><i>Students will know...</i> (DCI and Evidence Statements)</p> <p>Gravitational Force Weight</p>	<p><i>Students will be able...</i> (SEP and CCC)</p> <p>Constructing Explanations and Designing Solutions Develop and Using Models Analyze and Interpret Data</p>

Mass Sun Moon Planet Galaxy Milky Way Asteroid Comet	Systems and System Models Stability and Change Scale, Proportion, Quantity
---------------------------------------------------------------------------	-------------------------------------------------------------------------------------------------------

Part 2: Three-Dimensional Assessment using UbD Stage 2

In Stage 2 of UbD, teachers determined the evidence needed to indicate if students have met the desired results identified in Stage 1, including:

- How will we know if students have achieved the desired results?
- How will we assess student’s ability to transfer their learning to new situations?
- How will we monitor the development of understanding and provide meaningful feedback?

To identify the evidence needed, teachers established anchoring phenomena that illuminated the essential question. The questions the students ask about the anchor drive the learning within the unit; therefore, the anchor should be complex and require an understanding of several big science ideas to explain.

Teachers also created guided notes and review sheets that organized and supported the construction of explanations. In addition, teachers helped students prepare for assessments and identified assessment phenomena that solidified understanding of the essential question and assessed students’ abilities to transfer their learning to new situations.

Finally, teachers created assessments where questions build on Bloom’s Taxonomy (such as recall, analyze, apply, compare, evaluate, develop, etc.) and included prompts using the language of the CCCs (cause and effect, structure and function, systems, scale, stability and change, energy and matter, patterns). In doing so, students were provided opportunities to use primary source documents, data tables, graphs, etc. to complete Claim Evidence Reasoning (CER) activities (Krajcik, 2007).

Table 4: Completed Stage 2 modified UbD Template

UbD Stage 2 – Acceptable Evidence (Formative and Summative)
<p>What evidence will show that students understand?</p> <p><i>Performance Tasks:</i></p> <p><u>Anchoring Phenomenon</u></p> <p>Planet Jumping: Using a data table provided students will determine which planet you would result in the shortest to highest vertical jump on and explain why.</p> <p><u>Phenomenal Assessment</u></p> <p>CER - Rocket Ship Launch The same rocket is taking off from three different planets (each with different masses). Which rocket will need the most fuel at lift-off? Justify your answer.</p> <p>CER - Changing Tides How does the distance of the moon to the Earth affect the ocean tides?</p>
<p>What other evidence needs to be collected in light of Stage 1 desired results?</p> <p><i>Other Evidence:</i> Students will recall unit terminology. Students will be able to identify properties of objects of the solar system.</p> <p>Student will be able to answer question similar, but not limited to:</p> <ul style="list-style-type: none"> ★ What is gravity? ★ What two variables can affect the force of gravity on an object? ★ Is there gravity in space? Give evidence to support your claim. ★ If all objects really do accelerate downward the same (due to gravity pulling down) why does a leaf fall slower than a wood block? ★ If you were floating in space, why would a scale read your weight as "0"? ★ Why doesn't your mass also change when you go into space? ★ What is weight? ★ Why will you weigh less on the moon than on Earth? ★ Why is the moon more affected by Earth's gravity than Jupiter? ★ What would happen if the Earth/Universe did not have any gravity?
<p>Opportunities for Student Self-Assessment and Reflection</p> <p>Unit test Exit tickets Kahoot Quizlet Terminology Outlines Quizziz Graphic Organizer for Phenomena</p>

As shown in Table 4, teachers created formative and summative assessments that allowed students to recall terminology, analyze and create models, analyze data, conduct further research, draw conclusions, and design solutions.

Part 3: Unit Planning Using the UbD and 5Es

Stage 3 of UbD consisted of planning learning experiences and instruction. The activities selected gave numerous opportunities for students to draw inferences and uncover terminology. Students were provided the freedom to actively construct meaning (question), refine understanding (gather), and apply their learning to new situations (transfer). When selecting activities, the teachers considered the following questions:

- What knowledge and skills will students need to achieve desired results?
- How will we prepare them to transfer their learning?
- What activities and resources are best suited to accomplish our goals?

Using the 5-Es learning approach (engage, explore, explain, elaborate, evaluate; Bybee, 2017) and the other instructional models of Gather, Reason, Communicate (GRC), Claim Evidence Reasoning (CER), and Question Formulation Technique (QFT), the teachers established a routine where students understood their role in learning and performance. Students soon understood that they must use the material provided to them to construct their own understanding, which increased their depth of exploration.

Table 5: Stage 3 modified UbD Template

Stage 3 – Learning Experiences and Instruction		
Question (Phenomenon)	Engage Phenomena/Problem/ Anchoring Experience	
Gather (Construct Explanations and Carry Out Investigations)	Explore Hands-on/Minds-on	
	Explain Direct Instruction	

Transfer (Engage in Argument from Evidence)	Elaborate	
	Evaluate	
Resources		

Findings

After using this modified UbD template for two years to implement a three-dimensional learning approach in planning and instruction, surveys were administered to teachers and students to analyze its impact. The following feedback was collected from teachers and students:

Significant Findings from Teachers:

“The modified UbD template acted as a life preserver in unpredictable tides.”

“The Stage 1 template, along with color coding, greatly assisted the unpacking of the standards, and increased my ability to visualize connections of PEs across specialty areas (Physical, Life, Earth and Space).”

“By breaking down DCIs into key concepts, I was able to see the reduction in breadth of content. I myself could now take a deep breath and figure out a way to get my students to dig deeper.”

“Identifying performance tasks based on anchoring and assessment phenomena tied the big picture together. Stage 2 acted as a springboard for my instructional planning.”

“I have used the 5Es before, but by using all three stages of UbD with the 5Es, I was able to ensure my planning allowed my students to obtain a deeper understanding of required PEs.”

Significant Findings from Students:

198 intermediate students enrolled in a course participating in this curriculum redesign project completed a voluntary survey. Student interest in different areas of science were evenly distributed among this group. 82% of the students enjoyed learning different areas of science.

92% of the students associated their learning experiences with their success on assessments, not just their ability to memorize facts (See Figure 1 below).

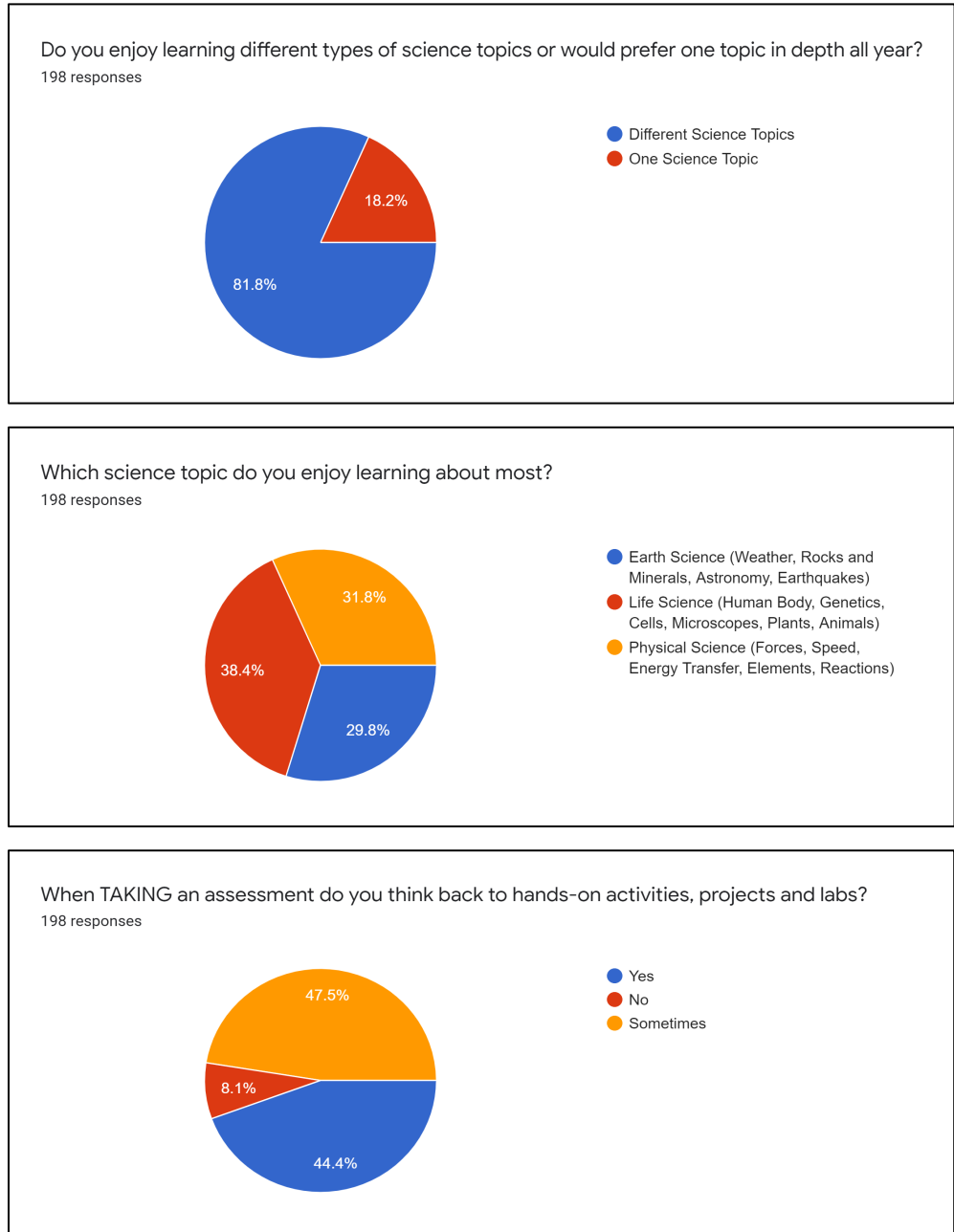

Figure 1: Results of Student Surveys

Conclusion

Unfortunately, the world that students and teachers coexist in is one of uncertainty with an unpredictable future. Therefore, teachers need to find a way to identify strategies that develop

students' conceptual understanding of content, positively influence student achievement, and establish a growth mindset for all involved in the learning process. The shifts are not easy; however, the more we embrace the mindset of three-dimensional learning with the assistance of UbD, the more we can see a transformation in both ourselves and our students.

“There are still days where we have to push and pull information, but there are also days where we see the spark of wonder return...and that makes it all worth it...that spark transforms our planning and instruction to play with intention.” – Carol-Ann Winans, Director of Science and Technology, Wantagh School District

Acknowledgements

Carol-Ann would like to acknowledge the teachers involved in this project: Thomas Vereline, Phyllis Murphy, Elyse Longo, and Ashley Azzata.

About the Author

Carol-Ann Winans taught Living Environment for 13 years and now serves as the Director of Science and Technology for the Wantagh School District. The Wantagh School District is dedicated to advancing STEM education. She is very appreciative of the support given to the teachers to advance their craft and work to maintain curiosity. She is passionate about the benefits of shifting towards three dimensional instruction to advance an appreciation for the nature of science. She currently serves as the Director of the Nassau Section of STANYS and is thankful to the Nassau and Suffolk sections, as well as LISTEMLA, for their ongoing support of successful implementation of NYSSLS. She can be contacted via email at nassaudirector@stanys.org.

References

- Bybee, R., Moulding, B. (2017). *Teaching science is phenomenal*. Washington, UT: ELM Tree Publishing.
- Hattie, J. (2009). *Visible learning: A synthesis of over 800 meta-analyses relating to achievement*. London: Routledge.
- Lotto, R. B. (2017). *Deviate: The science of seeing differently*. Boston, MA: Hachette Books.
- New York State P-12 Science Learning Standards. (n.d.). Retrieved from <http://www.nysed.gov/common/nysed/files/programs/curriculum-instruction/p-12-science-learning-standards.pdf>
- NGSS Lead States (2013). *Next Generation Science Standards: For States, by States*, Washington, DC: National Academies Press.
- Phenomena for NGSS. (n.d.). Retrieved from <https://www.ngssphenomena.com/>
- SCALE. (n.d.). Curriculum: Stanford NGSS Curriculum & Assessment. Stanford University, Stanford, California. Retrieved from www.scienceeducation.stanford.edu/curriculum
- Wiggins, G. P., & McTighe, J. (2008). *Understanding by design*. Alexandria, VA: Association for Supervision and Curriculum Development.

Instructional Insights for Using Water Circuit Analogies for Learning Introductory Circuits

Kevin Gee

Abstract

Electric circuits is more difficult for students to understand than mechanics in introductory physics due to the fact that the movement of charges in electric circuits is invisible (Saeli & MacIsaac, 2007). A water circuit analogy may be useful in building student understanding and addressing common misperceptions about electric circuits. The applicability and limitations of the water circuit analogy are discussed. Recommendations for the economical sourcing of parts are offered.

Introduction

This paper explores the use of water circuits as analogies for helping students in introductory physics classes understand electrical circuits. Analogies can be useful in building understanding by mapping a more-familiar source concept to a less-familiar target concept (J. Clement, 1993). Observing macroscopic flows can be an initial step towards imagining the flows of charge carriers in the electrical circuit that cannot be directly observed (Saeli & MacIsaac, 2007).

Addressing Common Student Misconceptions

Analogies can form an important bridge from students' prior knowledge and pre-conceptions to expert models of physics, even compared to formal proofs and empirical investigations. Prior knowledge is best invoked early in the curriculum to create more coherent lessons. Analogous phenomena can form inspiration for students to explore both the domain and range of their models and test previously developed conceptions in a more concrete fashion.

Many students maintain models of electricity for which closed circuits are not necessary in order for electrical devices to operate. It is very straightforward for students to see that the water circuit will only function if a loop is formed with the plastic tubing and that water will only flow through each element if it is correctly placed in the loop.

One of the most common misconceptions held by students is that batteries function as sources of constant current rather than constant voltage (Engelhardt & Beichner, 2004). It should

be intuitive to most students that the flow produced by the pump is not constant but depends on the load of resistors in the circuit. Even if this idea is not intuitive, the change in flow through the water circuit can easily be observed by watching the flow meters.

A related misconception is the idea that batteries act as a pure source of electrons or that the batteries are “filled up” with current that is released as the batteries operate (Korganci, Miron, Dafinei, & Antohe, 2015; Shaffer & McDermott, 1992). It should be clear to students that water is not stored in the pump, but that the pump serves to circulate the water through the circuit. Care should be taken to explain that the reservoir is not a part of the battery in the analogy but functions like electrical ground.

The water circuit can also help address the misconception that current is somehow “used up” by loads in an electrical circuit (Korganci et al., 2015; Shaffer & McDermott, 1992). The water circuit allows students to see that the flow of water into circuit elements must equal the flow of water out of the elements in the steady state. Running the water circuit without refilling the reservoir also makes it clear that the amount of water or charge is conserved (See Table 1 for a list of analogies between water circuit and electrical circuit).

Table 1. Analogies between water circuit and electrical circuit

<i>Water Circuit</i>	<i>::</i>	<i>Electrical Circuit</i>	<i>Limitations</i>
<i>Water</i>	<i>::</i>	Charge carriers	Water pressure does not have polarity
<i>Water pump</i>	<i>::</i>	Battery	Energy consumption of battery goes to zero as resistance goes to infinity while energy consumption of pump does not
<i>Tubes</i>	<i>::</i>	Wires	Water flows through entire area of tube, while excess charge flows on surface of wire
<i>Reservoir</i>	<i>::</i>	Electrical ground	
<i>Scouring pad packed tube</i>	<i>::</i>	Resistor	
<i>Water flow rate</i>	<i>::</i>	Current	No analogy to magnetic fields with water flow
<i>Hydrostatic head</i>	<i>::</i>	Voltage	Head can only be positive, while voltage has polarity
<i>Vertical open tube</i>	<i>::</i>	Voltmeter	Open tube holds water, while voltmeter does not hold charge
<i>Water flow meter</i>	<i>::</i>	Ammeter	Water flow meter has non-negligible resistance, while ammeter does not
<i>Clamp</i>	<i>::</i>	Switch	

Apparatus

Figure 1(a) and Figure 1(b) show the completed water circuit apparatus. Table 2 and Figure 2 contain a list of the parts and sources needed to build the apparatus for the learning activities described later. The submersible pump, in this analogy, acts as the battery in an electric circuit. The plastic tubing plays the role of wires. Tubes packed with scouring pads act analogously to resistors. Impeller-type visual flow meters act as ammeters in a circuit. Open-ended vertical tubes show the potential. The water rises to different heights above the reservoir to show the pressure at various points in the circuit. Switches can be replicated by folding over the tubing and holding it in place with clamps or using more sophisticated in-line valves.

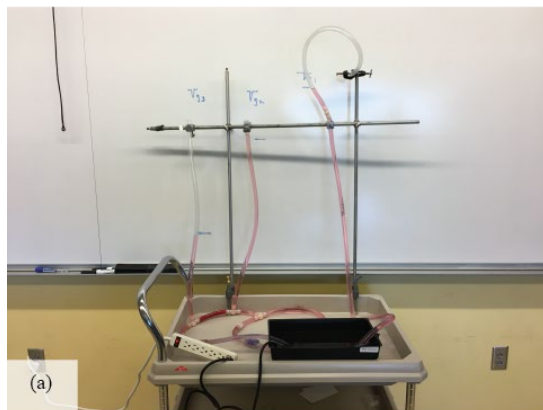

Figure 1(a) and 1(b). Front and top view of completed water circuit

This water circuit is different from other designs (Pfister, 2004) in that there is an open reservoir and open tubes to show potential. The Pfister design is completely enclosed and uses mechanical pressure meters in the place of open tubes. The flow of water through the circuit is evident from the turning impellers of the flow meters rather than the flow of glitter. Also, the hydrostatic pressure can be observed in the height of the water in each open tube, rather than from the analog gauges of pressure meters.

Figure 2. Photos of select components: (a) water pump, (b) plastic tubing, (c) barb connectors and adapters, (d) scrub pad "resistors", (e) visual flow meter, (f) reservoir

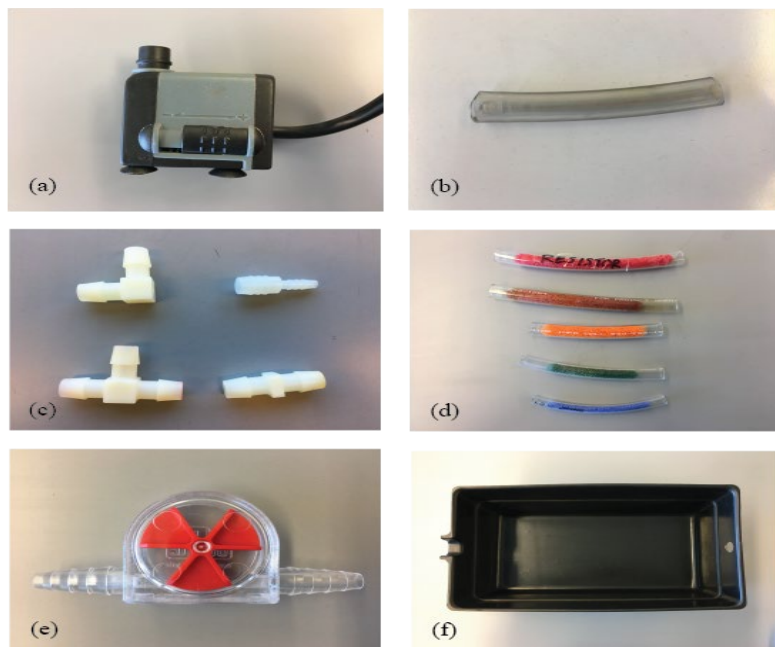

Table 2. Sourcing for water circuit components

Component	Cost	Part Number	Manufacturer	Vendor URL
Submersible fountain pump	\$26.00	WT125P	FountainPro	Fountainpro.com
Visual flow meter	\$15.00	8720-1002	Burkle	Thomassci.com
0.5 in. ID x 10 ft. clear vinyl tubing	\$5.20	T10006010	UDP	Homedepot.com
3/8 in. ID x 10 ft. clear vinyl tubing	\$4.30	T10006008	UDP	Homedepot.com
4X 0.5 in. x 3/8 in. reducing coupler	\$4.00	C8-6NK	Eldon James	Grainger.com
0.5 in. T connector	\$4.00	800389	Everbilt	Homedepot.com
0.5 in. Y connector	\$3.30	Y0-8HDPE	Eldon James	Grainger.com
Scouring pads	\$4.00	88HD-CC	Scotch-Brite	Lowe's.com
2X table clamps	\$160.00	H-8265	Humboldt	Thomassci.com
Ring stand support rods	\$22.00	H-21470	Humboldt	Thomassci.com
5X perpendicular clamp holders	\$40.00	RCLBH1	United Scientific Supplies	Thomassci.com
Food coloring	\$4.00	52100071077	McCormick	Target.com

Suggested Student Learning Activities

Table 3 lists the applicable *NYS P-12 Science Learning Standards* (NYSED, 2016). Note that the K-12 Framework (National Research Council, 2012) does not explicitly address circuits aside from being in a general category of energy conversion devices. However, the NYSSLS directly calls for instruction in Ohm's Law.

Table 3. NYS P-12 Science Learning Standards (2016) and A Framework for K-12 Science Education (2012) relevant to the water circuit analogy

Standard	Explanation
HS-PS3-1	Create a computational model to calculate the change in the energy of one component in a system when the change in energy of the other component(s) and energy flows in and out of the system are known.
HS-PS3-2	Develop and use models to illustrate that energy at the macroscopic scale can be accounted for as a combination of energy associated with the motions of particles (objects) and energy associated with the relative position of particles (objects).
HS-PS3-3	Design, build, and refine a device that works within given constraints to convert one form of energy into another form of energy.
HS-PS3-5	Develop and use a model of two objects interacting through electric or magnetic fields to illustrate the forces between objects and the changes in energy of the objects due to the interaction.
HS-PS3-6	Analyze data to support the claim that Ohm's Law describes the mathematical relationship among the potential difference, current, and resistance of an electric circuit.

Students will benefit from hands-on experimentation with the water circuit side-by-side with the equivalent electrical circuit over perhaps a three-lesson period. Students should be encouraged to map analogous elements and observations from the two circuits. However, explicitly tabulating analogous elements as in Table 1 should be delayed until sufficient student discourse and experimentation has taken place. Guided worksheets could provide scaffolding to encourage students to identify both the domain over which the analogies are applicable and the cases where the analogies do not apply. Particular care should be taken to discuss the domain (applicable

areas) and range (non-applicable or inconsistent areas) of any analogies identified by students (See Appendix A and Appendix B for student worksheets and an answer key).

Series Water Circuit

Figure 3 shows a hydraulic schematic for a water circuit in a series configuration and its analogous electrical circuit schematic. Building and observing these circuits addresses the misconception that current is consumed by devices in the circuit. Students should observe that the flows through both flow meters and the flows in and out of the entire circuit are roughly the same, reflecting the conservation of moving charge carriers within the electrical circuit (AMTA, 2017). It also makes it clear that the potential is increased by the pump and becomes lower with each successive device in the circuit. The sponge resistors can be replaced by ones of different lengths. Students should observe that P_2 and P_3 are affected by this change, but P_1 and P_4 are not.

Figure 3. Schematic of series (a) water circuit and (b) electrical circuit

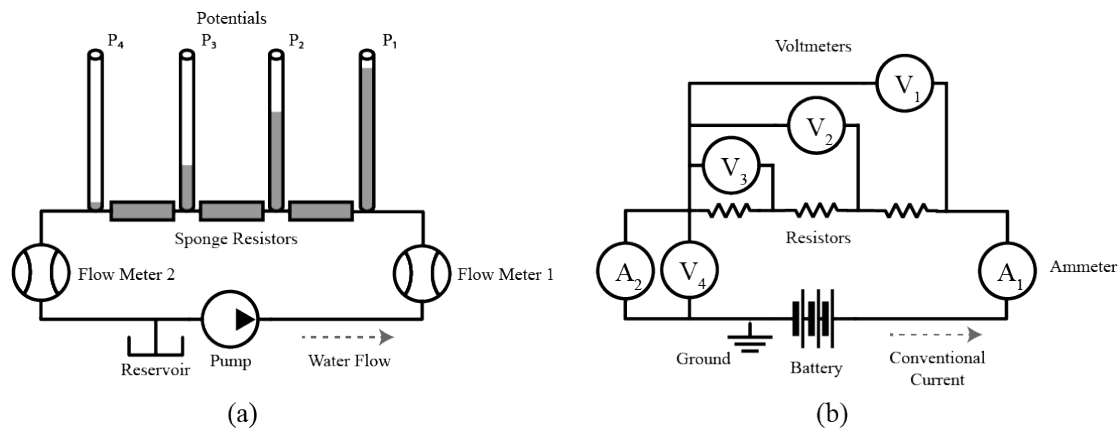

Parallel Water Circuit

Figure 4 depicts a water circuit in a parallel configuration and its analogous electrical circuit. Students can experiment with using different resistances for the scrub pad resistors to see their effect on the potentials and flows. Students should observe that increasing the length of the scouring pad resistors reduces the flow in each branch. They should connect this conceptually with the reduction in current caused by increasing the resistance in each branch of the equivalent electrical circuit, according to Ohm's Law.

Figure 4. Schematic of parallel (a) water circuit and (b) electrical circuit

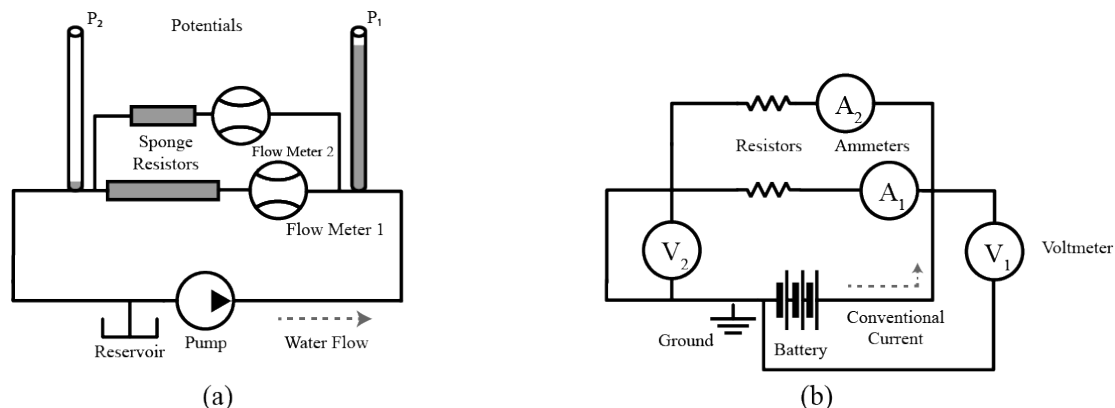

The parallel water circuit is also a good opportunity to look for equivalence to Kirchoff's Laws: Students should observe that the net change in potential along any loop is zero and that the net flow of water into any junction always equals the net flow out of that same junction.

Switched Water Circuit

Figure 5 shows a water and electrical circuit that can be switched from a series configuration to a mixed series and parallel configuration. In this activity, students could predict the change in the flow meters and in the potential P_2 . Students can see the increase in cross-sectional area of the parallel portion of the circuit when the switch is closed. Predicting the behavior of this hybrid series/parallel circuit requires more mastery of the series and parallel circuit models than the simpler activities described earlier (Chabay & Sherwood, 2002). However, starting and stopping the flow may cause non-equilibrium behavior in the water circuit that is similar to that seen in RC circuits (MacIsaac, Ward, & Wilser, 2019).

Figure 5. Schematic of switched (a) water circuit and (b) electrical circuit

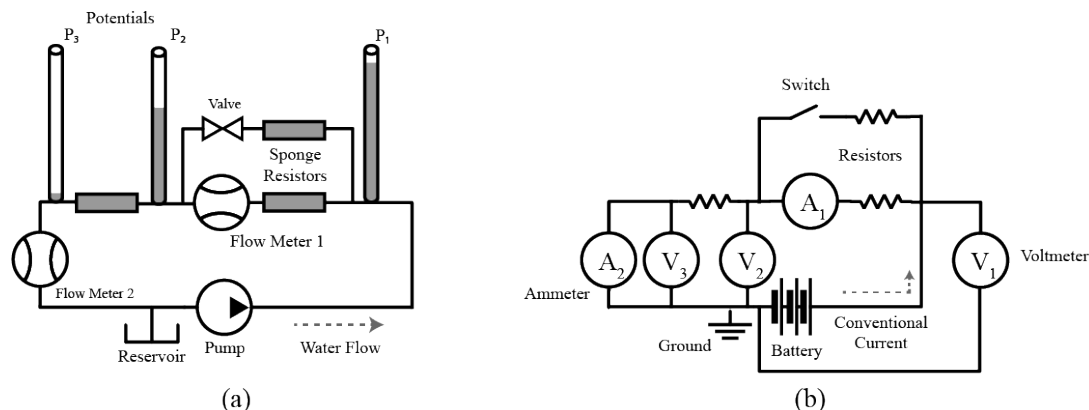

Construction and Sourcing of Apparatus

Water circuits are not typically found in high school and undergraduate physics classrooms. Water circuit classroom demonstration kits were available from a limited number of vendors. The individual components have been difficult to source after the kits were no longer offered. The impeller-type flow meters, in particular, were only available from a limited number of suppliers that stopped carrying the products. However, flow meters made for lab use, consumer aquariums and personal computer liquid cooling applications can now be sourced inexpensively. Clear plastic tubing and barbed connectors can be sourced from home improvement and hardware stores.

The glitter water circuit described in (Pfister, 2004) used a slightly exotic salvaged slush pump that is resistant to clogging by the glitter. If glitter is not used in the water circuit, then any low-cost aquarium water pump can be used. Pumps and related plumbing are available for cooling personal computers. However, some of the higher end products can approach the cost of industrial equipment.

Impeller-type water flow meters do not directly provide numerical data. However, the rotation rate of the impellers can be measured using slow-motion video analysis, or by counting revolutions while timing with a stopwatch. There are also flow meters available with reed switches that can be instrumented with the appropriate interface.

Domain and Range of Analogy

As previously stated, Table 1 summarizes analogous attributes of the water and electrical circuit. Analogies are only applicable across a specific range. The water and DC circuit analogy holds most closely in equating Poiseuille's Law to Ohm's Law where the flow rate and change in hydraulic head take the place of current and the change in voltage, respectively (Nave, 2017). Poiseuille's Law relates the resistance to flow and flow rate of fluids in laminar flow conditions. Pressure in the water circuit (as a ratio of energy to volume) equates to voltage (the ratio of energy to charge) in the electrical circuit. Electrical ground can be equated to a hydraulic reservoir (Saeli & MacIsaac, 2007).

While the water circuit analogy can help students understand the behavior of electrical circuits, the analogy should not be extended to where it does not apply (J. Clement, 1993). Students refine their understanding both where analogies are valid and where they do not apply (J. J. Clement, 2013). For instance, the working fluid in the water circuit occupies the entire volume of the tubing, while the excess charge carriers in an electrical circuit exist primarily on the surface of conductors.

Students may observe a small time-delay from when the pump is turned on until water flows back into the reservoir after completing the circuit. However, charge carriers begin to circulate almost instantaneously when the battery is connected in an equivalent electric circuit. This delay could be considered outside the range of the analogy or it could be modeled as a small parasitic capacitance in the water circuit.

The analogy also breaks down in that there is no equivalent to positive and negative charge in the water circuit. However, the potentials can have an arbitrary zero reference point in both cases. Students will notice when building water circuits that the water can be casually shaken out of the apparatus. Charge carriers cannot be easily shaken out of conductors in electrical circuits. However, the Tolman-Stewart Effect (Arons, 1997) shows that accelerating conductors can result in displacement of the mobile charge carriers within the conductors.

Conclusion

The increased availability of low-cost flow meters and water pumps makes it more cost-effective to use the water circuit analogy in the introductory physics classroom. Water circuits

link the visible behavior of fluids to the behavior of invisible charge carriers in an electrical circuit. Using vertical tubes to measure potential in the water circuit links students' intuition of gravitational potential to electrical potential. Several water circuits can be built along with their equivalent electrical circuits as part of a sequence of learning activities to address common misconceptions relating to passive circuits.

I have used the water circuit analogy in two settings, so far: First during a teacher professional development workshop (as a teacher-student), and second as a review while teaching Regents Physics. The Regents Physics class used it as part of a mini-lab over a video conferencing link during a school building closure. In both cases, students were exposed to the idea of **liftage** as gravitational potential prior to the circuits unit. Students were able to use this to bridge from their prior knowledge to a model of circuits. A video conference is certainly less than ideal for this type of lab exploration. Students were able to interact with the circuit with the instructor as proxy through the video link and complete the lab successfully.

In the future, I would use the water circuit analogy either as an extension to an initial treatment of circuits, or as an end-of-year review. The water circuit can be introduced during the initial treatment if students are struggling with particular ideas within circuits. Students can explore the water circuit in more depth until the ideas are solidified. The water circuit makes an ideal end-of-year review because it refreshes student understanding of both gravitational and electrical potential.

Acknowledgements

I would like to thank Dr. Dan MacIsaac for his help and guidance in preparing this manuscript. I would also like to thank Dr. David Abbott for sourcing and building the prototype water circuit apparatus. Without them this paper would not have been possible.

About the Author

Kevin Gee is a second-career physics teacher coming from an 18-year career as a high-tech product manager in Silicon Valley. He earned a BSc Physics from SUNY Binghamton, a MSc Electrical and Computer Engineering from UC Santa Barbara, and is completing his MS Ed Physics (7-12) with Alternative Certification Pathway at SUNY Buffalo State (December 2020, expected). Kevin can be reached via email at geekm01@mail.buffalostate.edu.

References

- AMTA. (2017). Modeling instruction curriculum: Physics second semester E&M. Retrieved from *modelinginstruction.org*
- Arons, A. B. (1997). *Teaching Introductory Physics*. New York: John Wiley & Sons, Inc.
- Chabay, R., & Sherwood, B. (2002). *Matter and Interactions Vol. II* (4th ed.). New York: John Wiley & Sons, Inc.
- Clement, J. (1993). Clement Bridging Analogies. *Journal of Research in Science Teaching*, 30(10), 1241–1257.
- Clement, J. J. (2013). Roles for explanatory models and analogies in conceptual change. *International Handbook of Research on Conceptual Change*, 412–446.
- Engelhardt, P. V., & Beichner, R. J. (2004). Students' understanding of direct current resistive electrical circuits. *American Journal of Physics*, 72(1), 98–115.
- Korganci, N., Miron, C., Dafinei, A., & Antohe, S. (2015). The Importance of inquiry-based learning on electric circuit models for conceptual understanding. *Procedia - Social and Behavioral Sciences*, 191, 2463–2468.
- MacIsaac, D., Ward, A., & Wilser, S. (2019). A classroom demonstration RC circuit: The neon bulb relaxation oscillator. *The Science Teachers Bulletin*, 83(1), 29–39.
- Nave, C. R. (2017). Water Analogy to DC Circuits. Retrieved from <http://hyperphysics.phy-astr.gsu.edu/hbase/electric/watcir.html>
- NRC (National Research Council). (2012). *A Framework for K-12 Science Education: Practices, Crosscutting Concepts, and Core Ideas*. *A Framework for K-12 Science Education: Practices, Crosscutting Concepts, and Core Ideas*. Washington, DC: National Academies Press.
- NYSED. (2016). New York State P-12 Science Learning Standards. Retrieved from <http://www.nysed.gov/common/nysed/files/programs/curriculum-instruction/hs-science-learning-standards.pdf>

Pfister, H. (2004). Illustrating Electric Circuit Concepts with the Glitter Circuit. *The Physics Teacher*, 42(6), 359–363.

Saeli, S., & MacIsaac, D. (2007). Using Gravitational Analogies to Introduce Elementary Electrical Field Theory Concepts. *The Physics Teacher*, 45(2), 104–108.

Shaffer, P., & McDermott, L. (1992). Research as a guide for curriculum development: An example from introductory electricity. Part II: Design of instructional strategies. *American Journal of Physics*, 60(11), 1003–1013.

Appendix A: Student Worksheets

Name: _____ Per: _____ Date: _____

Water Circuit Analogy

Learning Objectives

- Model Ohm's Law describing relationship between resistance, potential drop, and current for any circuit element.
- Model Kirchhoff's Laws for total potential change around loop and flows in and out of junctions.
- Understand energy changes in electrical and mechanical systems.

Before the Water Circuit is Powered-On

1. Take some time to inspect the different parts of the water circuit. Identify the water pump, plastic tubing, "resistors", flow meters, vertical tubes, and reservoir.
2. Make a diagram of a "resistor" used in the water circuit.
3. Predict what will happen to the water in the circuit when the pump is powered-on.
4. Do you think water will fill the vertical tubes? How high do you think the water will go in each tube? Why?
5. How fast do you think each of the flow meters will spin? Will they spin the same or different speeds? Why?

Once the Water Circuit is Running

6. Observe what happens once the water circuit is running. Do your observations match your predictions?
7. Write the terms for electrical circuits that are analogous to each water circuit term and your reasoning in the chart below.

Water Circuit	Electrical Circuit	Reasoning
Water		
Water pump		
Tubes		
Reservoir		
Scrubber-filled tube		
Water flow rate		
Water pressure		
Vertical open tube		
Water flow meter		
Clamp		

Electrical Circuit Terms: wires, switch, voltmeter, ammeter, voltage, resistor, battery, electrical ground, charge carriers, electrical current

Name: _____ Per: _____ Date: _____

Water Circuit Analogy Questions

Directions

- Divide into groups to discuss two to three problems per group
- Each group will present answers to class

1. If voltage is in units of energy per unit charge, what is the equation for the potential energy per unit mass in gravitational fields (or *liftage*)? (Hint: $PE = m g \Delta h$)
2. How would you compare the role of the pump in the water circuit with a battery in an electrical circuit?
3. What do the “resistors” do to the flow of water in the water circuit? How does this compare to what a resistor does in an electrical circuit?
4. Do any parts of the water circuit “use up” water (cause it to be permanently consumed)? What does this mean for charge carriers in an electrical circuit?
5. What happens to the water in the water circuit right after the pump is turned on or off? Do you think something similar happens in electrical circuits?
6. Where does the energy for the water circuit come from? Where does it go as the circuit is running?
7. How is energy transformed in the water circuit? Is there anything that uses water to transform energy in your own life?
8. A water circuit is formed by connecting a high “resistance” tube in series with a low “resistance” tube. a) How would you compare the flow rates through each tube? b) How would the flow rates change if you connected the tubes in parallel?

9. If the flow of water through the water circuit is closed off (by squeezing it shut or closing a valve), does water keep coming out of the vertical tube while the pump is operating, or does it stop? Why? How does this compare to opening a switch in a DC electrical circuit?
10. What would happen to the water in the vertical tubes of the water circuit if there were no “resistors” in the circuit? Does something analogous happen to a DC circuit with no resistors in it?
11. **[CHALLENGE QUESTION]** What moves faster, the water in the water circuit, or the charge in an electrical circuit?

Appendix B: Student Worksheet Answer Key

Name: _____ Per: _____ Date: _____

Water Circuit Analogy Questions Key

Directions

- Divide into groups to discuss two to three problems per group
- Each group will present answers to class

1. If voltage is in units of energy per unit charge, what is the equation for the potential energy per unit mass in gravitational fields (or *liftage*)? (Hint: $PE = m g \Delta h$)

Full credit: Liftage = $\Sigma PE / m = g \Delta h$

this is analogous to

$$V = \Sigma PE / q = E \Delta h$$

for an electric circuit.

Partial credit: Liftage = $\Sigma PE / m$

2. How would you compare the role of the pump in the water circuit with a battery in an electrical circuit?

Full credit: The pump and battery both provide energy to the water and electrical circuits, respectively.

Partial credit: The pump pushes the water and the pump pushes the electrons in the circuit.

3. What do the “resistors” do to the flow of water in the water circuit? How does this compare to what a resistor does in an electrical circuit?

Full credit: The resistors impede the flow of water in the water circuit. Resistors in an electrical circuit impede the flow of charged electrons.

Partial credit: Answers with the terms “slow down”, “get in the way of”, or similar.

4. Do any parts of the water circuit “use up” water (cause it to be permanently consumed)?

What does this mean for charge carriers in an electrical circuit?

Full credit: The elements of the water circuit and electrical circuit do not consume water or charge, respectively. Circuit elements such as reservoirs in the water circuit or capacitors in an electrical circuit may temporarily store water or charge, but they do not consume it.

Water from the water circuit may leak or spill out of the circuit, but this does not happen with electrical circuits.

Partial credit: Answers using the terms “conservation” or “conserved”.

5. What happens to the water in the water circuit right after the pump is turned on or off? Do you think something similar happens in electrical circuits?

Full credit: It will fluctuate up and down. Something similar happens in electrical circuits in the form of stray capacitance. This is caused by electric fields that can cause charge to build up in certain parts of the circuit. These charges can move when the circuit is not in steady state equilibrium.

Partial credit: Answers suggesting that the charge carriers will fluctuate in some way.

6. Where does the energy for the water circuit come from? Where does it go as the circuit is running?

Full credit: The energy for the water circuit comes from the wall outlet in the form of electrical energy for the water pump. The energy primarily becomes thermal energy of the water in the circuit.

Partial credit: Answers suggesting electricity as an energy source.

7. How is energy transformed in the water circuit? Is there anything that uses water to transform energy in your own life?

Full credit: Electrical energy from the wall outlet becomes: kinetic energy of the moving water, gravitational potential energy of the water-earth system, elastic potential energy of the tubes stretching, and thermal energy of the water in the circuit. The geological water cycle, hydroelectric power plants, and the electrical appliances in the home are examples of systems that transform energy using water.

Partial credit: Answers involving the terms “kinetic energy” or “potential energy”.

8. A water circuit is formed by connecting a high “resistance” tube in series with a low “resistance” tube. a) How would you compare the flow rates through each tube? b) How would the flow rates change if you connected the tubes in parallel?

Full credit: The flow rates through each tube connected in series must be the same due to conservation of current (Kirchhoff’s Laws). If the same tubes are connected in parallel the total flow rate through the circuit will increase. $I = V/R$, $R_{EQ1}=R_1+R_2 > R_{EQ2}=R_1R_2 / (R_1+R_2)$, so $I_1 < I_2$

Partial credit: Answers suggesting the flow will be greater in the parallel case and that provide some reasoning.

9. If the flow of water through the water circuit is closed off (by squeezing it shut or closing a valve), does water keep coming out of the vertical tube while the pump is operating, or does it stop? Why? How does this compare to opening a switch in a DC electrical circuit?

Full credit: The water will rise in the vertical tubes until the hydrostatic head at the base of the tubes equals the pressure caused by the water in the vertical tubes. The height of the water in the vertical tubes will fluctuate until the circuit reaches equilibrium. This is analogous to charge being stored in an electrical circuit by stray capacitance. When an electrical switch is first opened the circuit is not at equilibrium. The charges in the circuit

will oscillate in a similar manner (see RC circuits for more information).

Partial credit: Answers that recognize that the water “sloshes” or fluctuates, and that similar behavior might happen with the charge carriers in an electrical circuit.

10. What would happen to the water in the vertical tubes of the water circuit if there were no “resistors” in the circuit? Does something analogous happen to a DC circuit with no resistors in it?

Full credit: If there were no resistors in the water circuit the water would not rise in the vertical tubes because the pressure change would be too small. If there were no resistors in an electrical circuit the circuit would be in a short-circuit condition. The current in the short-circuit would be limited only by the internal resistance of the battery.

Partial credit: Answers that suggest that the water or electrons will flow more quickly.

11. [CHALLENGE QUESTION] What moves faster, the water in the water circuit, or the charge in an electrical circuit?

(Young and Freedman, 2014, University Physics, p. 822) if the cross-sectional area of a typical electrical wire is $A = \pi d^2/4$, the current density $J = I/A$, gives a drift velocity of:

$$v_d = \frac{J}{n|q|} = \frac{2.04 \times 10^6 \text{ A/m}^2}{(8.5 \times 10^{28} \text{ m}^{-3})(-1.60 \times 10^{-19} \text{ C})}$$
$$= 0.15 \text{ mm/s}$$

The velocity of water is about $5 \times 10^{-2} \text{ m/s}$ in the water circuit. The water flows through the water circuit about 30X faster than the excess charge carriers (electrons) flow through a typical electrical circuit.

Building a Model of Optical Diffraction and Interference for High School Students Using Multiple Inquiry-based Physics Activities

Quinn Thomson

Abstract

In this paper, I present a series of activities directed toward high school regents physics students with the intent of having them investigate concepts behind and practical applications of diffraction and interference, as well as expanding their skills in scientific inquiry. Using experimental guides (Appendices A and C), students are required to make observations and collect data in order to answer questions that help them explore the physical effects of these concepts. Ultimately, students are asked to create and complete their own experiments as a method to assess their understanding of the topics and give them the opportunity to practice the scientific process (Appendices B and D). Several other professionals in my school and I noted that these activities helped facilitate student engagement with the topic and led to discussions between themselves and with the instructor. After these activities, students were able to answer previous NYS Regents questions on the subject with 96% accuracy.

Introduction

With the recent implementation of the *Next Generation Science Standards* (NGSS, 2013) and the *New York State P-2 Science Learning Standards* (NYSSLS, 2016), a focus has been placed on inquiry-based science education. My goal is to make a series of student activities that use the standards listed in the NYSSLS to have students gain an understanding of diffraction and interference. These activities are a mixture of guided inquiry experiments and full inquiry (i.e. student led) experiments. In these guided inquiry experiments students are given a simple procedure and asked questions based on what they observe and analysis. The student led experiments are when I give students a goal but offer no procedure requiring students to use their understanding so far to complete that goal.

Scientific inquiry is characterized by the NYSSLS by:

“A common set of values that include: logical thinking, precision, open-mindedness, objectivity, skepticism, replicability of results, and honest and ethical reporting of findings” (p. 64).

These guided inquiry experiments follow these values and have students record their observations and work through tougher questions using their observations to help them. By using multiple activities, students can replicate their results in a variety of different ways. Across the

NYSSLS, students are asked to demonstrate they understand how to “Plan and conduct investigations” across multiple subjects. During these activities, students were asked to formulate their own experiments and deal with their own misconceptions with the evidence of their experiments. Student found their own evidence in order to make logical conclusions.

The NYSSLS (HS-PS4-3) state:

“Evaluate the claims, evidence, and reasoning behind the idea that electromagnetic radiation can be described either by a wave model or a particle model (quantum theory), and that for some situations one model is more useful than the other.

[Clarification Statement: Emphasis is on how the experimental evidence supports the claim and how a theory is generally modified in light of new evidence. Examples of a phenomenon could include resonance, interference, diffraction, and photoelectric effect]” (p. 62).

These activities are designed to give students a closer look at interference and diffraction through experimental evidence. Students are asked to describe and reason with these phenomena using the wave model of light.

Background on Diffraction

Diffraction is the bending of waves around the edges of a barrier. The most common examples of diffraction are the bending of sound waves around an open-door as in Figure 1 or the bending of ocean waves around a barrier as shown in Figure 2.

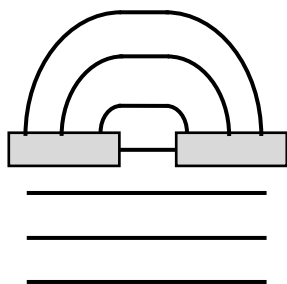

Figure 1.
Diffraction through
a slit

Interference is when two waves are at the same place at the same time. Unlike matter, waves have nothing preventing them from being superimposed. There are two types of interference: constructive and destructive. These are distinct based on what we observe when they are on top of one another. Constructive interference is when two or more waves form an apparent wave with a higher amplitude than either of the original waves, while destructive interference creates a wave with a smaller amplitude as seen in Figure 3.

Huygens' Principle can be used to explain diffraction. Huygens' Principle states that every point on a wavefront is a source of new waves (often referred to as wavelets) (Knight, 2013). When there are no barriers, these new waves end up interfering and canceling each other out along the entire wavefront, creating just a single wavefront as seen in Figure 4; however, when a wavefront comes across a thin barrier, slit, or multiple slits, the waves no longer cancel out their interference and a new pattern emerges that we refer to as diffraction.

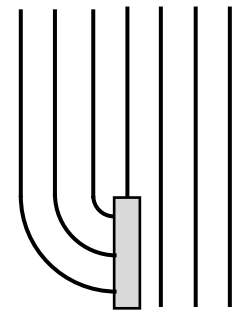

Figure 2. Diffraction around a barrier

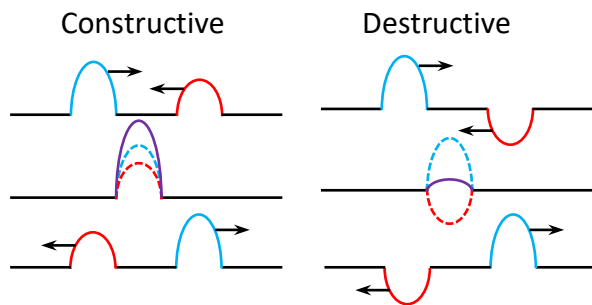

Figure 3. Pulse Interference

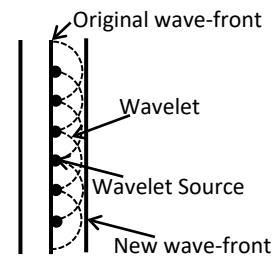

Figure 4. Huygens' Principle of a moving wave

In the first activity, we are using the effects of Huygens' Principle in action with human hair. As the light rays strike the hair, it prevents some of the wavelets from passing while on the sides of the hair, and they begin to diffract (Messer, 2018). The waves formed on each side of the hair begin to interfere causing a pattern of constructive and destructive interference seen in Figure 5. Looking at this “interference pattern” is the main point of the activity, as it gives us information about the object or opening that created it.



Figure 5. Hair interference pattern

This is also where the first major misconception for this activity is introduced. Many students assume the pattern created is the “shadow” of the hair on the board as shown in Figure 6. The early activities are made to show that this is not what is happening.

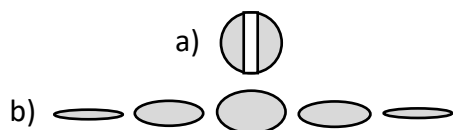

Figure 6. Possible hair results:
a) shows results expected for the “shadow” misconception of hair blocking light
b) shows the actual results

The gap between the pencils is what is acting as the opening in this activity, which is key because it allows students to adjust the size of the slit. One of the key factors in these series of activities is how the pattern gives us information on the slit or barrier that created it. With these pencils, students can adjust the size of the slit, thus changing the pattern. The relationship they should see is that as the gap between the pencils gets smaller, the pattern becomes more spread out as shown in Figure 8 (Teng, Teng & Hennekens, 2018). For students this is most likely an unexpected relationship as they often believe the bigger gap leads to a bigger pattern (McDermott, 2000). By using Huygens’ Principle, we can see why this inverse relationship occurs (Knight, 2013). Remember – if a wavefront does not come across anything, it remains a wavefront as the wavelets interfere

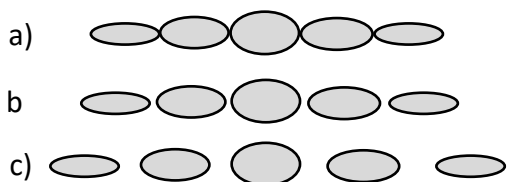

Figure 8: Changing pattern of pencil activity:
a) Large starting gap
b) Gap slight closed
c) Gap pitched nearly closed

The double pencil activity offers a different look at diffraction by changing out a barrier with an opening. Using Huygens’ Principle, we can see why these two seemingly different scenarios, a barrier and opening, result in the same pattern. As the wave front reaches the opening, wavelets can spread out, as some of the wave is blocked, resulting in the same thing as the hair as seen in Figure 7 (Knight, 2013).

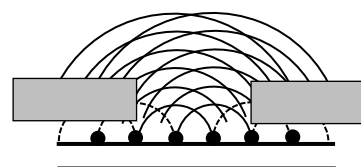

Figure 7. Huygens’ Principle of single slit diffraction

with themselves resulting in a wave that is not changed. When the gap is larger, more of the waves pass through unaffected, leaving the pattern smaller. Conversely, when the gap is smaller, the wave spreads out more making a more obvious pattern.

The wire mesh works off a similar principle as the previous activities. In this activity the meshes are two-dimensional, unlike the hair and pencil opening which act one dimensionally. This leads to a two-dimensional pattern on the screen. As seen in Figure 9, as the mesh gets finer the pattern gets larger, similar to the pencil opening. There is an interesting secondary pattern that emerges on the screen where the dots of the main pattern fade in and out. This is due to the thickness of the wires, while the main pattern forms based on the size of the gaps. This secondary pattern is not important within the goals of the activity, but students might notice it, so it is worthwhile to be able to answer any questions regarding this.

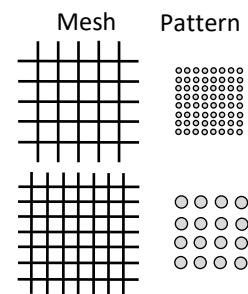

Figure 9. As the mesh gets finer the pattern gets larger and more spaced.

The next half of activity starts to focus more on double slit and diffraction grating interference and their associated formula. This equation comes from Young and his experiment with two slits (Knight, 2013). Figure 10 has the basic form of a double slit experiment where a laser interacts with two slits separated by distance d and projects an interference pattern on a nearby screen. Equation 1, based Young's experiment, used throughout these later activities. An important part of this equation to understand is that variable m is denotes which bright spot will be used in the measurements where $m = 0$ shows the center, $m = 1$ is for the spots above and below and so on. In order to find the θ in the equation, students need to measure the length to the

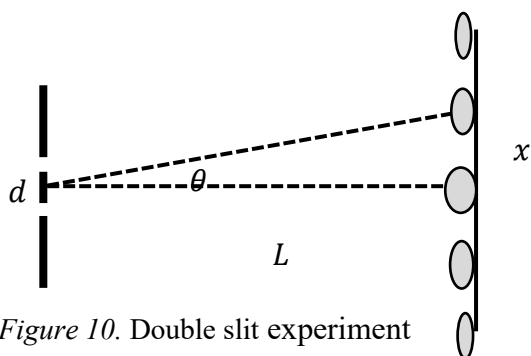

Figure 10. Double slit experiment

screen and the distance between bright spots. The basic trigonometric relationship is: $\tan(\theta) = x/L$ (Deweerd, 2016). d is often the goal of the activity due to the fact it is normally too small to measure without the aid of diffraction.

Equation 1

$$d * \sin(\theta) = m * \lambda$$

d : distance between slits
 m : what bright spot that is being measured.
 θ : Shown on figure 6
 λ : Wavelength of laser

CDs and DVDs are encoded with information by burning small dot like divots onto the surface as seen in Figure 11. This information is read by firing a laser through the disk in order to “read” these dots and extract information from the size and position of the dots. By removing the cover from a disk, students are able to fire a laser through the disk which cause it to

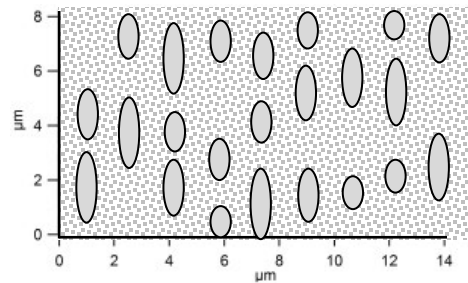

Figure 11. Microscopic view of a CD

diffract based on the separation of the grooves that this data forms. These grooves are placed so close together they act as a diffraction grating, which is when there are multiple slits next to one other. The double slit equation applies to diffraction gratings as well as CD and DVDs and can be used to calculate the spacing between the grooves (Nöldeke, 1990). Students calculate that the grooves of a DVD are closer together which shows them that more data can fit on a DVD than a CD. Note the actual value of the spacing of a CD is about 1.6µm and a DVD is .74µm.

The next two activities use very similar principles as the activity before; however, it uses a circular shape to create a diffraction pattern. The lycopodium powder and the red blood cells

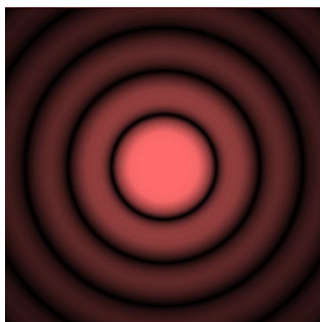

Figure 12. Airy diffraction pattern

both act as a collection of small circular apertures that form a circular pattern as seen in Figure 12 often referred to as an “Airy Disk.” The big difference between this and a standard diffraction grating is the values of m will not be simple integer values. The simple answer to why they are not integer values is that the radii of the minima and maxima spots are not evenly spaced like they are in other forms of diffraction. This uneven spacing causes the m values to also not be even. The more

complicated answer involves using Equation 2 in order to solve for the maxima and minima locations which require the use of a Bessel function (Sethuraman 2014). Table 1 shows the values for m to use in Equation 1. The

Equation 2

$$I(\theta) = I_0 \left[\frac{2J_1(kd \sin\theta)}{kd \sin\theta} \right]^2$$

I : light intensity
 I_0 : light intensity at the center
 k : is the wavenumber
 d : is the radius of the aperture (powder or cell)
 J_1 : is the Bessel function order 1

diameter of a lycopodium particle is around 36.8 μm (Sethuraman, 2014) and the diameter of a

red blood cell can vary greatly but typically falls between 7.5 to 8.7 μm (Diez-Silva et. al., 2010).

<i>m</i> values for:		
	Minima	Maxima
1	1.220	1.635
2	2.233	2.679
3	3.238	3.690

Table 1. m Values for Airy Disk

Materials and Safety Concerns

Each student group is going to need the following to complete all activities. Simple office supplies like rulers, index cards, pencils and rubbers bands are used as well. A class set of materials costs around \$100 with the exception of the lasers which depend greatly on the brand, style and power you purchase:

- Laser
 - Any color works; however, a variety of colors would be best so groups can see how different wavelengths effect the patterns
 - A laser that sits flat with a toggle switch makes it easier for students to make the patterns
 - <https://laserclassroom.com/product/laser-blox-multi-3-pack/>
- Fine Metal Meshes
 - Often called metal mesh or wire cloth
 - You need 3 different sizes
 - A mesh count of 60 to 120 (number of wires crossings per square inch) should be enough
 - https://www.amazon.com/Activists-Stainless-Steel-Screen-Filtration/dp/B07T5DWP99/ref=sr_1_20?keywords=Activists&qid=1572823108&sr=8-20
- Lycopodium Powder
 - <https://www.fishersci.com/shop/products/lycopodium-4/S25396>
- A slide with blood cells
 - <https://www.carolina.com/histology-microscope-slides/human-blood-film-slide-smear-he/313152.pr?question=>
- CD and DVD
 - Strip away the cover part of the disk, leaving it see- through

- The disk needs to have data
- A sample holder
 - A wooden block with a slit cut into works

The main safety concern for the students conducting these activities is the lasers. It is important to stress the care while using lasers. There is no need for particularly powerful lasers in these experiments, but students should still be instructed on the main risks with using lasers. Of course, the number one concern is having the laser pointed into a student's eye. One of the advantages of this lab is that laser can be held on the table rather than in their hands. If you do not have a laser that can sit flat on a table and a toggle switch, I would also suggest a holder for the laser in these labs. Something to keep a rounded laser flat on the table and to keep the laser on. Also, Lycopodium Powder dust is a category 1 flammable solid. The covered slides are reasonably safe, but making the slides may highly flammable dust. Protective goggles should be used to avoid eye contact. Please read all safety information that is provided with the powder.

Activities

The handouts with the instructions for students are found on Appendices A through D. The guided activities found on appendices A and C walk students through a several observations of physical objects using diffraction and interference. The activity in part A just require students to take a qualitative look, where they need to look at the relationship between the object and the pattern that it creates. Qualitative activities end with the activity found on appendix B where students need to create their own experiment using this relationship. Appendix C starts the quantitative activities where they need to take careful data and use Equation 1 to find the size of objects. Likewise, in Appendix D students need to use a similar technique to find the size of a red blood cell by creating their own experiment. The students' ability to create and successfully analysis these experiments help determine if they understand the material.

Reflections on Qualitative Activities

I found these activities very useful for getting students to understand the basic physical relationships without allowing students to just use formulas without understanding the underlying physics. The first activity where students view the interference pattern created by hair was gave students little trouble. I found that it allowed students to know what pattern they

are looking for in future activities. Something that was worth mentioning to the students is they do not have to yank their hair out, just brush their hands through their hair and they are bound to get a loose strand or two. After reviewing the results of the activities, the pencil activity was one of the toughest for students to understand. Many students had trouble identifying the interference pattern due to the challenging nature of making the gap between the pencils small enough to show changes the pattern, while holding it steady. Because this aspect of the activity is so important to the students' basic understanding of the concept, I stepped in to discuss the groups' results and make sure they were focusing on the correct phenomena. Telling or showing the students beforehand what pattern to expect may lessen this problem.

The mesh activity was very smooth, and students got great results with little help. I did use a zoomed in photo of the mesh next to a ruler to show students how to properly count the wires (See Figure 13). Students can use either their own phones or a microscope to better see the fine mesh.

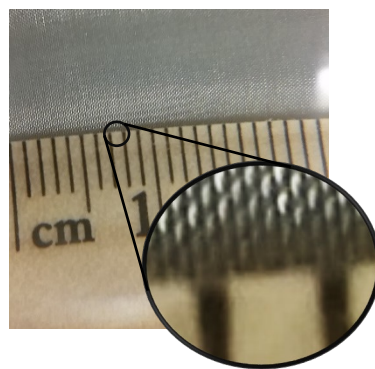

Figure 13. Zoomed in view of a ruler on mesh

The capstone challenge was successful overall. Students were able to construct a working experiment and the vast majority, 83%, were able to specify the proper relationship between the pattern and the object. The biggest misconception that I noticed was that students still believed the dim spots were the shadows of the hair. In this experiment, many measured not the distance between bright spots like the mesh activity, but only measured the very small width of a dim spot, which was often less than a millimeter. Although the correct answers can be achieved with this data, it is indicative of a misunderstanding how the pattern is formed. To combat this issue, I would suggest having a discussion with students on how they answer the “shadow” questions before the capstone challenge.

Reflections on Qualitative Activities

The qualitative activities were also quite successful. Overall, students were able to use the things they learned in the previous activities plus Equation 1 to find the sizes of different objects. With the CD/ DVD activity, students not only calculated the spacing difference between the two disks but also discussed how that could make them work differently. Many struggled with using the equation for the first time. I found asking them to draw triangles that represent

the path of the light helped them visualize what they needed to find the angle. Some students also needed assistance finding the value of m . Using a diffraction grating as an example, I showed the students how each dot relates to specific value of m and had them compare it to their observations of the disks.

The Lycopodium powder activity went smoothly for students. The only part that was tough for students was dealing with the different shape of the pattern and how to relate it to the other activities. The circular pattern means they need to change the values of m they use to nonwhole numbers. By this point, students were able to correctly draw the relationship between pattern and object with 89% accuracy. It was also helpful to tell them beforehand to measure to the center of either the dark rings or the light rings rather than the edge.

In the final activity, all groups were successful in finding the size of a red blood cell. By the end of the activity I could tell students were very proud of the fact that they were able to measure something so small in an experiment that they made themselves. The average size of red blood cell is 7.5 to 8.7 μm and students results ranged from 4 to 12 μm .

Student and Professional Feedback

Overall, I received a lot of positive feedback from students and other professionals when conducting these activities in the classroom. Students reported that they enjoyed the activities and it was easy to see the joy they got from completing the final activity without any predetermined procedure or help. During the first two activities, some students struggled with the limited instruction; however, as the lessons continued, they got significantly more comfortable with the idea of inquiry activities. The two areas where my students seemed to struggle the most was the new unit prefixes in these activities and converting between them and using equation 1. Although I practice unit conversion during the beginning of the year, the addition of micrometers and nanometers led to some confusion. This is my students' first experience with trigonometry in physics and this equation in particular is difficult to understand at first. Even with the difficulty of these new concepts, these activities led to some great interactions between the students and instructors.

Another physics teacher and my school's administrator observed these activities in action. My administrator found the activities to be "highly effective" at engaging students in

effective discussions. He also noted that these activities had students “actively participating by measuring, documenting, calculating, and setting up the testing devices.” Another physics teacher, whose interpretation of these activities helped inspire my own instruction, found these activities “useful in helping the students understand the material and its real-world applications, such as its use in the discovery of DNA.”

Conclusion

Students do not often get to work with the diffraction and interference of light and when they do, they are often not asked to explain the relationship between these concepts and the patterns they create (Arons, 1997). These activities give students the chance to not only create these patterns with many different setups, but they are asked to find the subtle differences between them. They are asked to explain, draw pictures and discuss what they are seeing which provides students a chance to really learn and use the concepts.

Before I used these activities, diffraction and interference was a quick lesson where I lectured to my students, gave a teacher run demonstration, and asked example questions; however, when my students conducted these activities, they had great discussions within the activities and showed some genuine excitement at the results of their independent investigations. These types of inquiry activities are great at promoting this type of engagement with students and I am glad I have switched how I teach this concept, even when it takes a bit longer to do. Overall, these activities brought a lot of excitement to the classroom and students had a genuine good time using the lasers to experience some weird and unexpected phenomena.

Acknowledgements

This paper is submitted in partial fulfillment of the requirements necessary for PHY690: Masters Project at SUNY – Buffalo State College under the guidance of Dr. Dan MacIsaac. Edited by Joshua Feldhousen.

About the Author

Quinn Thomson graduated from SUNY Geneseo with a double major in physics and adolescent education as well as a minor in chemistry. He started his teaching career at JFK High School in Cheektowaga, NY for three years teaching physics, chemistry and as well as

other science electives. He is currently in graduate school at Buffalo State pursuing his master's in physics education. Quinn is currently working at Orchard Park High School as a physics teacher and can be reached via email at qbraxo@gmail.com.

References

- Arons, A. B. (1997). *Teaching introductory physics*. New York: John Wiley & Sons.
- Braun, G., Tierney, D., & Schmitzer, H. (2011). How Rosalind Franklin discovered the helical structure of DNA: Experiments in diffraction. *The Physics Teacher*, 49(3), 140-143.
- Curry, S. M., & Schawlow, A. L. (1974). Measuring the diameter of a hair by diffraction. *American Journal of Physics*, 42(5), 412-413.
- Deweerd, A. J. (2016). CD, DVD, and Blu-Ray disc diffraction with a laser ray box. *The Physics Teacher*, 54(5), 300-301.
- Diez-Silva, M., Dao, M., Han, J., Lim, C.T., & Suresh, S. (2010). Shape and biomechanical characteristics of human red blood cells in health and disease. *MRS Bulletin*, 35(5), 382–388.
- Kim, H. (2016). Inquiry-based science and technology enrichment program for middle school-aged female students. *Journal of Science Education and Technology*, 25(2), 174-186.
- Knight, R. D. (2013). *Physics for scientists and engineers: a strategic approach*. Boston, MA: Addison-Wesley.
- Kruglak, H., & Campbell, D. (1983). Color perception with diffraction gratings. *The Physics Teacher*, 21(5), 312-314.
- Messer, R. (2018). Single slit interference made easy with a strand of hair and a laser. *The Physics Teacher*, 56(1), 58-59.
- Mungan, C. E. (2009). Approximation for the Rayleigh resolution of a circular aperture. *The Physics Teacher*, 47, 382–382.

- Narayanan, V. Anantha. (1996) Low-cost diffraction experiment. *The Physics Teacher*, 34, 382–382.
- New York State Education Department. (2016). *New York State P-12 Science Learning Standards*. Retrieved from <http://www.nysed.gov/common/nysed/files/programs/curriculum-instruction/p-12-science-learning-standardsupdated10-18.pdf>
- NGSS Lead States. (2013). *Next Generation Science Standards: For States, By States*. Washington, DC: The National Academies Press.
- Nikitin, S. (2010). On the problem of the diffraction pattern visibility in laser diffractometry of red blood cells. *Quantum Electron*, 40, 1074.
- Nöldeke, C. (1990). Compact disc diffraction. *The Physics Teacher*, 28(7), 484-485.
- Renganathan, B., Viswanathan, A., Sastikumar, D., & Hameed, S. S. (2007). Measurement of particle size of Lycopodium powder using He-Ne laser. In *Laser Science* (p. LThB5). Optical Society of America.
- Sethuraman, J. (2014). Determination of mean particle size of lycopodium powder - An experiment. Salem, Tamil Nadu: Vinayaka Mission's Kirupananda Variyar Engineering College.
- Teng, B., Teng, P., & Hennekens, C. H. (2018). A simple way to teach single slit diffraction based on edge diffraction. *The Physics Teacher*, 56(6), 380-383.
- Thompson, J., Braun, G., Tierney, D., Wessels, L., Schmitzer, H., Rossa, B., Dultz, W. (2018). Rosalind Franklins X-ray photo of DNA as an undergraduate optical diffraction experiment. *American Journal of Physics*, 86(2), 95-104.
- Veal, W., & Sneed, K. (2014). Putting new life in an old lesson. *The Science Teacher*, 81(7), 47.
- Velentzas, A. (2014). Teaching diffraction of light and electrons: Classroom analogies to classic experiments. *The Physics Teacher*, 52(8), 493-496.

Vokos, S., Shaffer, P. S., Ambrose, B. S., & Mcdermott, L. C. (2000). Student understanding of the wave nature of matter: Diffraction and interference of particles. *American Journal of Physics*, 68(S1).

Appendix A. Qualitative Diffraction and Interference

The Strand of Hair:

Setup:

- Construct a sample holder using an index card with a square cut in it. Tape a piece of your hair so it goes across the opening. (shown below)
- Hold the sample about 2 meters away from a screen (our whiteboards)
- Fire the laser at through the hair and at the screen.

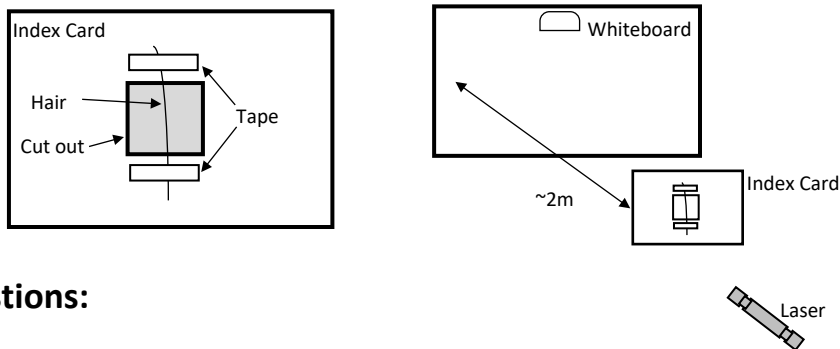

Questions:

1. Sketch the pattern the laser makes on the screen when hitting the hair.

2. Does the pattern on the screen just look like the “shadow” of the hair? Explain how it’s the same or different than just the “shadow.”

3. This experiment helps us see the property of waves known as diffraction. Explain what diffraction is and how we are seeing it in this experiment.

4. Rotate the hair by 90° and observe the pattern made by the laser now. How is the direction of the spread-out beam relative to the orientation of the hair?

Two Pencils:

Setup:

- Construct a narrow slit by attaching two number 2 pencils together using two rubber bands. It's important to have one section of the rubber bands in between the pencils. Wrap the band tightly so they are held closely together.

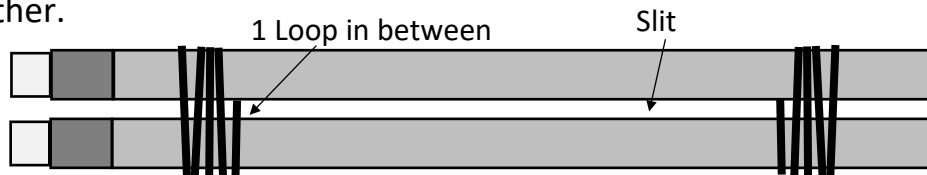

- Use the same setup as the last lab just replace the index card for the double pencils.

Questions:

1. Sketch the pattern the laser makes on the screen going through the slit.

2. Does the pattern on the screen just look like the “shadow” of the opening? Explain how it's the same or different than just the “shadow.”

3. Squeeze the pencils together to make the slit narrower. Describe how the pattern changes.

4. This experiment helps us see the property of waves known as interference. Explain what interference is and how we are seeing it in this experiment.

5. Describe the similarities between the pattern made by the hair and the one created by the slit.

Wire Meshes:

Setup:

Collect 4 different meshes. Use the provided sample holder and place them within them. Make a similar setup to the previous labs substituting for the mesh sample holder.

Measurements for Each Mesh:

- Using a ruler measure the separation between the bright spots of the pattern created on the screen.
- Using the magnifying lens and possibly the aid of your smart phone camera measure how many wires are in one millimeter of the mesh

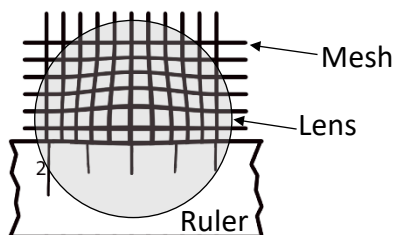

Questions:

1. Sketch the pattern the laser makes on the screen going the coarsest mesh and the finest mesh.

Coarsest Mesh

Finest Mesh

2. Complete the following data table based on your measurements

Mesh	Distance between nearest bright spots in the pattern (x)	Number of wires in one millimeter (n)	Distance between wires ($d=1/n$)
Coarse			
Medium			
Fine			
Finest			

3. How does the pattern change as the wires get closer together? What type of mathematical relationship is this?

Appendix B. Capstone Challenge: Who has the thickest hair?

Instructions: Construct and conduct an experiment to show which person in the group has the thickest hair and which has the thinnest.

1. Procedure:

2. Data/ Observations

3. Analysis: Write about why your data is important and how you use it to prove your conclusion

4. Conclusion

Appendix C. Quantitative Diffraction and Interference

DVD versus CD:

Background: CDs and DVDs act as a diffraction grating due to the incredible small parallel tracks burned into them. We are going to attempt to find the spacing between these tracks and compare CDs to DVDs.

Setup:

- Place the CD on the sample holder. Make sure that the bare section that is cut into the CD is visible.
- Place the CD with the holder close to the screen (about 20cm) and look for the pattern on the screen.
- NOTE: that small cracks in the CD can cause a second pattern from being formed, you are looking for the 3 to 5 dots being created.

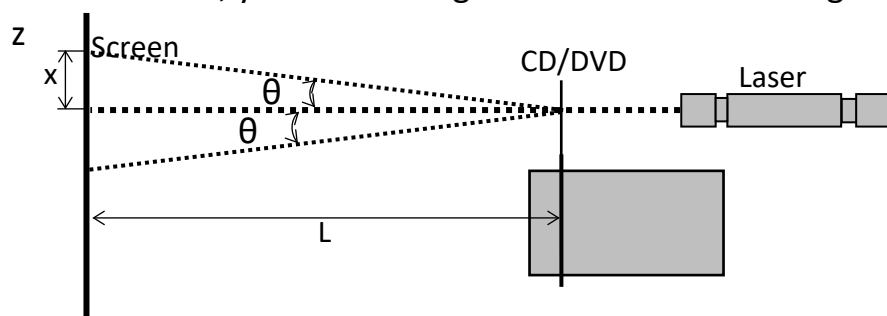

Measurements:

- With a ruler, measure the distance between the central dot and the first dot (x).
- Measure the distance between CD/ DVD and the screen (L).

Questions:

1. Based on the diagram above what trigonometric function should you use to relate x , L and θ ? Write out the complete formula for θ in terms of x and L .
2. Complete the data table below using your measurements and your trigonometric formula to find the angle.

Media	x (cm)	L (cm)	θ
CD			
DVD			

3. Using the double slit equation $m * \lambda = d * \sin(\theta)$ find the spacing between the tracks for the CD and DVD. Note that you can find wavelength of your laser on the written on the laser. Show all work below.

CD track spacing: _____ DVD track spacing: _____

4. Using the drawing below which shows CD under a microscope.
- Measure the horizontal space between the tracks below.
 - Calculate the percent difference between your measurement here and your calculated value above.
 - Make a quick sketch on how you predict the DVD track spacing will look like given the value you found above.

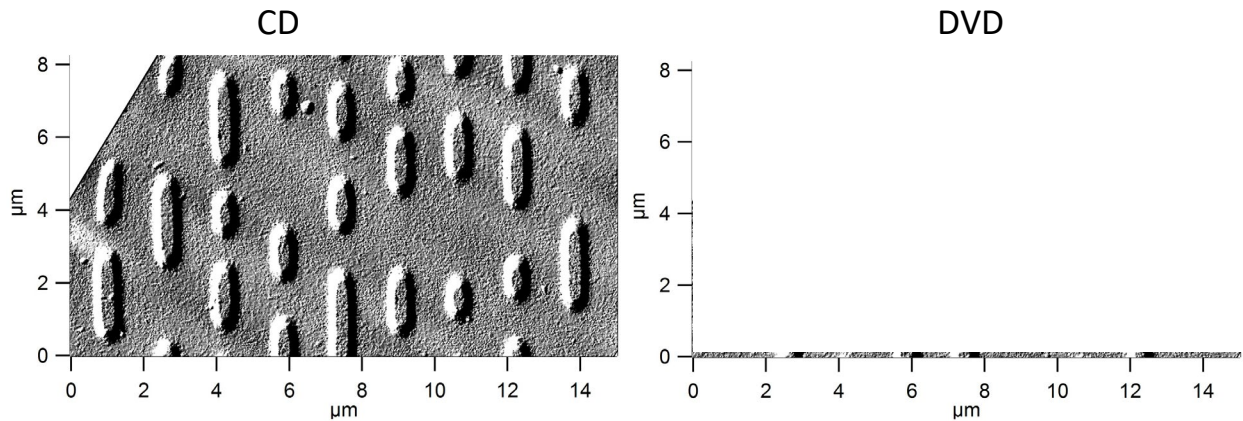

*CD Image courtesy of Freiermensch under GNU Free Documentation license

CD track spacing: _____

CD percent difference: _____

5. A CD can store 0.65 gigabytes whereas a DVD can store 4.7 gigabytes of information. How does the data and calculations you made show that DVD can store more information within the same size?

Lycopodium Powder:

Background: Lycopodium powder is made up of spores from clubmoss plants. These are very small and highly flammable in air. They are also roughly circular in shape.

Setup:

- Sprinkle a very small amount of lycopodium powder onto a glass slide. Title the slide over a waste beaker to remove excess powder. You should be left with a slide that is lightly dusted with the powder.
- Use the laser to view the diffraction pattern of the powder.

Observation: Draw the pattern you are detecting on the board, make sure to note the bright (Maxima) and dim (Minima) areas.

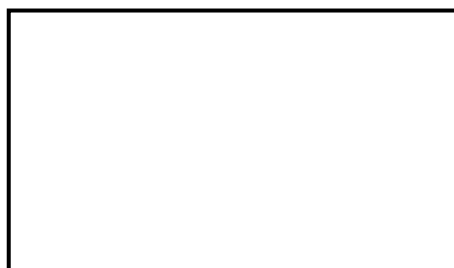

Measurements:

- With a ruler, measure diameter (D) of the first minima circle.
- Measure the distance between the slide and the screen (L).
- Laser Wavelengths (λ) are found on the lasers.

Questions:

1. Based on previous lab and your drawing above what trigonometric function should you use to relate D (the diameter of the circles), L and θ ? Write out the complete formula for θ in terms of D and L.

2. Complete the data table below using your measurements and your trigonometric formula to find the angle.

Laser Color	λ (nm)	L (cm)	Diameter (cm)	θ

3. What is the relationship between the wavelength and the diameter of the pattern?

4. Due to the fact that this is circular pattern the m values will not be whole and half integers in the diffraction formula: $m * \lambda = d * \sin(\theta)$. Instead we use the values shown on the chart below. Based on the diameter (D) you measured what value of m should you use?

m values for:		
	Minima	Maxima
1	1.220	1.635
2	2.233	2.679
3	3.238	3.690

5. Find using the data in your chart find the value for the diameter of the lycopodium powder spore (d) for each color of your laser. Show all work for the red laser.

Red Laser: _____ Green Laser: _____ Blue Laser: _____

6. Take the average of d and do a percent error calculation with the actual value of the diameter of a lycopodium powder spore ($33 \mu\text{m}$).

% Error: _____

7. If you were to test on object that had a bigger diameter, how would that change the interference pattern shown on the board? Do a quick sketch to show the pattern created by the lycopodium powder and this new bigger object to illustrate the difference.

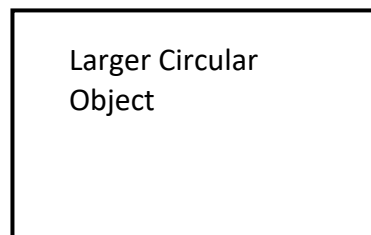
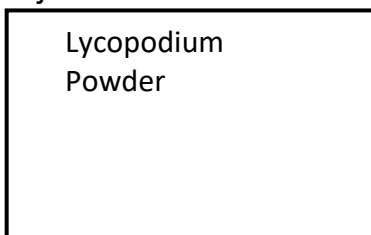

Appendix D. Capstone Challenge – Size of a Red Blood Cell

Instructions: Construct and conduct an experiment to find the size of a red blood cell.

1. Procedure

2. Data/ Observations

3. Analysis:

4. Conclusion

5. Question: Explain how diffraction and interference play a role in your experiment

The Buffalo State College Campus Geology Display: An Outdoor Geology Classroom

Gary S. Solar

Abstract

The Outdoor Geology Classroom on the campus of Buffalo State College provides an immersive field-like experience where students and visitors learn about Earth processes using a purposely arranged combination of natural and construction materials to represent the components and processes of the Rock Cycle. The display is intended as a centerpiece of the newly renovated/constructed Science and Mathematics Complex, but is more importantly a teaching tool that is used for introductory level class meetings and other geology instruction. The display is guided by signage and website support so visitors can learn from it without formal instruction. The location is adjacent to the entrance to the new Whitworth Ferguson Planetarium, so visitors to campus for planetarium events will inevitably interact with the display. This is an Outdoor Geology Classroom that is important to campus instruction, public relations, and recruiting alike.

Introduction

Geology is fundamentally an “outdoor” science. Earth materials like rocks, lava, and sediment are collectively the record of long-term Earth processes driven by the motion of tectonic plates. Naturally, geological field-based data and hypotheses are tested in laboratory settings, however the bulk of what undergoes testing comes from the field. Therefore, when it comes to effective teaching of geology and the broader Earth Sciences, it is necessary to incorporate as much field experiences as possible into the teaching of geology principles and processes.

Like at other campuses with geology and Earth Sciences degree programs, at Buffalo State field experience comes primarily from field trips, both near and far from campus (within the Buffalo-Niagara region and as far Europe and the Pacific coast). The farther away from campus, the more expensive and longer the time commitment. Some of this experience is augmented with visual aids in the classroom, and the effect of photography and illustrations cannot be understated. However, there is no adequate substitute for the ‘real thing’, so our department’s commitment to the field experience is unwavering.

At Buffalo State, we have been running a variety of field excursions for our students every year for more than 50 years now. However, not all students are able to participate due to some combination of personal commitments, financial situation, or physical limitations. Our

department is committed to these experiences, and in collaboration with the Buffalo State Geology and Astronomy Club, we support much of the expenses involved. Still, not everyone can participate.

Given this reality, department faculty have taken advantage of our campus to bridge the gap between in-class instruction and field excursions. I noted some years ago that on our campus there is a large number and variety of rocks from across the United States used for decorative stones (See Figure 1) and building materials, so I started to use these rocks as outside teaching materials.

As a useful tool, I mentored an undergraduate student in the production of a map and report including explanations of the rocks on campus (See Figure 2 below; Kinmartin, 2006). The map and explanation serves as a campus “rock arboretum.” This “rock arboretum” has been an important resource of natural examples of a large variety of rocks, minerals, fossils, and mineral patterns in rocks. Although the rocks of the “rock arboretum” are representative of the processes by which they formed (and of the place they were quarried, which is not known in almost every case), a limit of their use is that they are not arranged in any meaningful natural way (except as building materials), and are displaced from their natural setting. Therefore, these rocks cannot adequately reflect natural processes academically, at least not completely. As a solution, a process-oriented outdoor geology display would both (1) provide a spatial (field-like) relationship between materials used, and (2) foster more participatory learning than can be accomplished in a class or standard laboratory setting.



Figure 1. Commemorative display rock on the campus of Buffalo State College. The rock is granitic gneiss, and included in the “rock arboretum” documentation project conducted by Kinmartin (2006; see Figure 2).

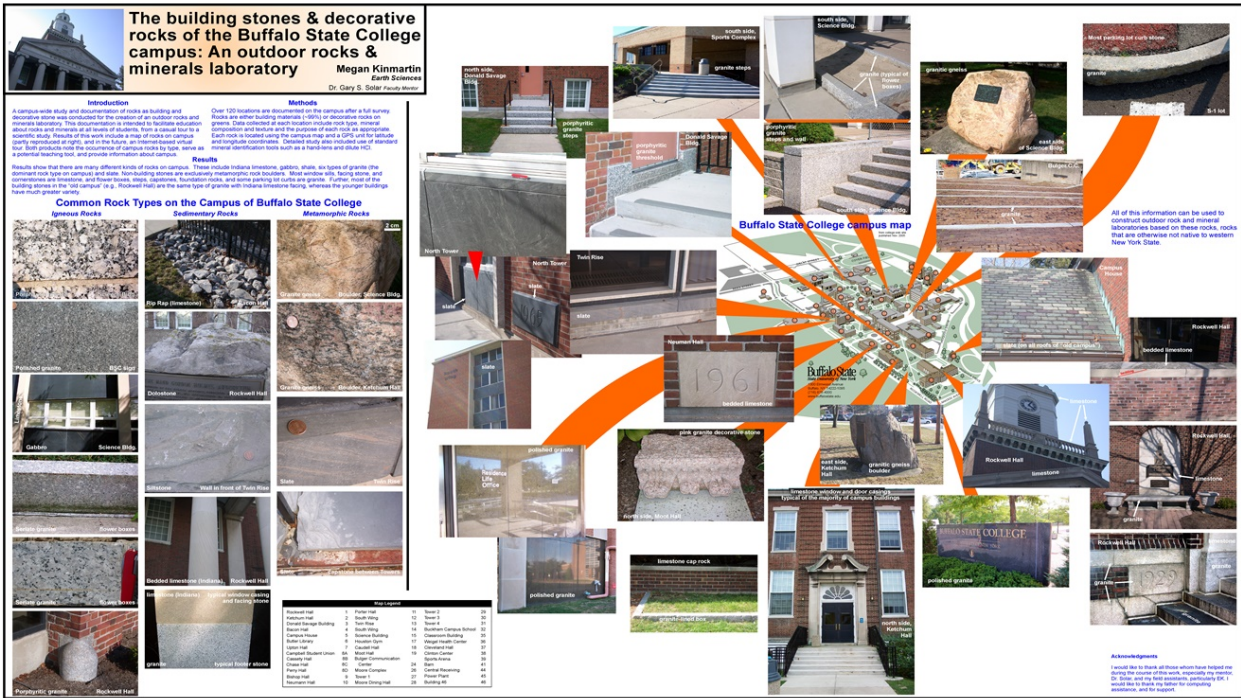

Figure 2. Poster (reproduced; original is 40 inches wide) of the Buffalo State College campus rocks and building materials perspective map with example materials images and explanation (Kinmartin, 2006). This is a documentation of the “rock arboretum” that exists on Buffalo State’s campus whose academic insufficiency is the lack of process relations between the rocks. The Outdoor Geology Classroom addresses that shortfall. To view this poster’s details, find an electronic copy at the Outdoor Geology Classroom page at <https://earthsciences.buffalostate.edu/>.

Taking advantage of funding for “science on display” as part of our campus’ renovation/construction of our integrated natural science building (i.e. the Science and Mathematics Complex), I designed an outdoor geology display area as both a series of things to examine and an engaging space where the things are arranged geologically – based on a simplified version of the Rock Cycle (See Figure 3). The Outdoor Geology Classroom display opened in summer 2020 (See Appendix A for photos). The concepts on display are those that students usually only interact with in two dimensions in textbooks and presentations. The display enables them to be within an immersive, three-dimensional presentation in much the same way that a museum would do it. Because students, staff, faculty, and visitors are able to sit and walk among the display at times when not being used for a class, it may get them thinking about rocks and the world around them. In this way, like all displays, the visibility of the sciences at Buffalo

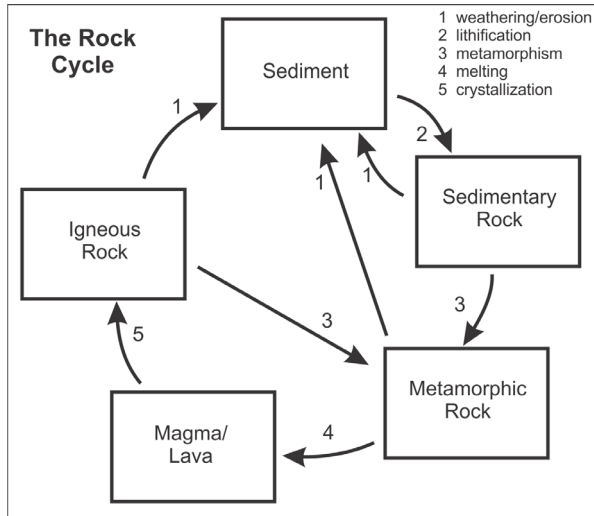

Figure 3. The simplified Rock Cycle. This illustration is the basic way the Rock Cycle is depicted in all introductory Geology and Earth Science textbooks. The numbered arrows are processes that connect the components (labeled rectangles), and correspond with the numbered arrows in Figures 4 and 5.

State is enhanced, but also this may serve to recruit both new majors to Earth Sciences and Geology, and applicants to Buffalo State.

Meeting the Learning Standards –High School Earth’s Systems

The Outdoor Geology Classroom is designed so that it will be “science on display” and useful for college instruction, but is also intended to be useful in meeting key High School Earth Science standards in the *New York State P-12 Science Learning Standards* (NYSSLS) (See Table 1).

Table 1. The NYSSLS Earth’s Systems High School Standards that can be met using the Buffalo State College rock-cycle-based outdoor classroom

NYSSLS in Earth Systems	Cross-cutting Concepts	Disciplinary Core Ideas
HS-ESS2-2: Feedback in Earth’s Systems	Stability and Change: Feedback (negative or positive) can stabilize or destabilize a system.	ESS2.A: Earth materials and systems: Earth’s systems, being dynamic and interacting, cause feedback effects that can increase or decrease the original changes.
HS-ESS2-3: Cycling of Matter in the Earth’s Interior	Energy and Matter: Energy drives the cycling of matter within and between systems.	ESS2.A: Earth materials and systems: Evidence from deep probes and seismic waves, reconstructions of historical changes in Earth’s surface and its magnetic field, and an understanding of physical and chemical processes lead to a model of Earth with a hot but solid inner core, a liquid outer core, a solid mantle and crust. Motions of the mantle and its plates occur primarily through thermal convection, which involves the cycling of matter due to the outward flow of energy from Earth’s interior and gravitational movement of denser materials toward the interior.

The “cross-cutting” concept of “Stability and Change” is addressed because the display is based on the Rock Cycle and depicts Earth component adjacencies. The contact between components in the display indicates processes that connect the components they represent. Figure 4 is a reproduction of the sign that is on display at the site. The map in the center of Figure 4 is enlarged in Figure 5 and features numbered arrows that correspond with connecting components of the rock cycle through rock cycle processes.

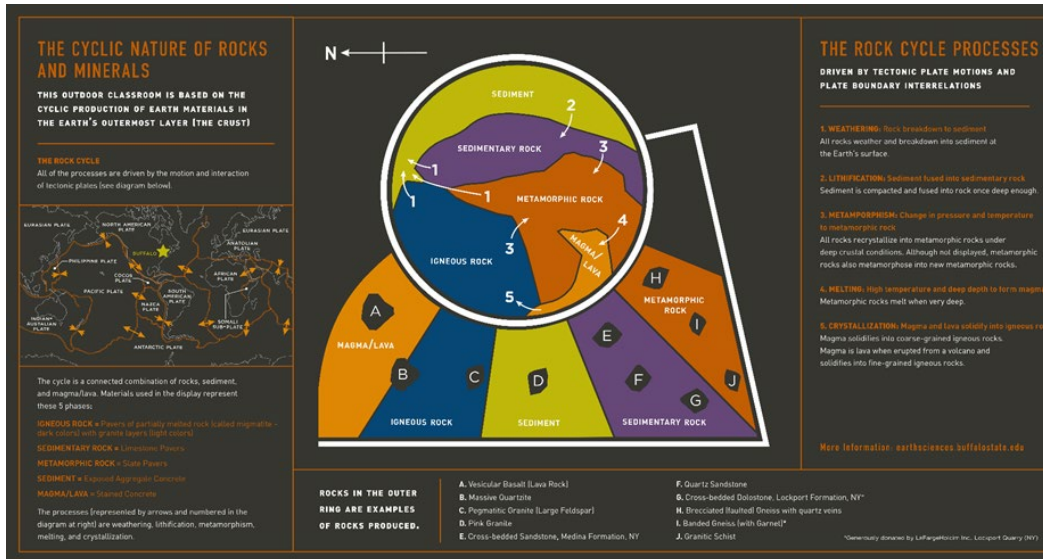

Figure 4. Reproduction of the signage at the site of the Science and Mathematics Complex Rock Cycle Outdoor Geology Classroom. The sign is 18” tall by 36” wide). To view it in detail, visit the Outdoor Geology Classroom, and find an electronic copy at the Outdoor Geology Classroom web page at <https://earthsciences.buffalostate.edu/>. See Figure 5 for an enlargement of the Rock Cycle color inset map at the center of the sign. The information in the left column is a brief explanation of the Rock Cycle, and its connection with Plate Tectonics. The map at the left is of the current plates on Earth and their motion directions. The lower left corner is a listing of the rock cycle components (rocks, sediment, and magma/lava). The right column is an explanation of the rock cycle processes as illustrated in the center map as numbered arrows, and as listed in Figure 3. The bottom box has a listing of the lettered boulders found in the outer arc around the circle. These include sandstones, granite, and gneisses of different varieties.

Again, because the display depicts the rock cycle, the “cross-cutting” concept of “Cycling of Matter in the Earth’s Interior” is also addressed. Interior Earth processes are most of the rock cycle, and, of course, the rock cycle is that “cycle” that connects the matter, well, cyclically. Further, the rock cycle is driven by the motion and subsequent interaction of tectonic plates (shown on the display signage; Figure 4, left), so participants with the Outdoor Geology

Classroom may be helped to meet the standards with guidance and designed activities with an instructor.

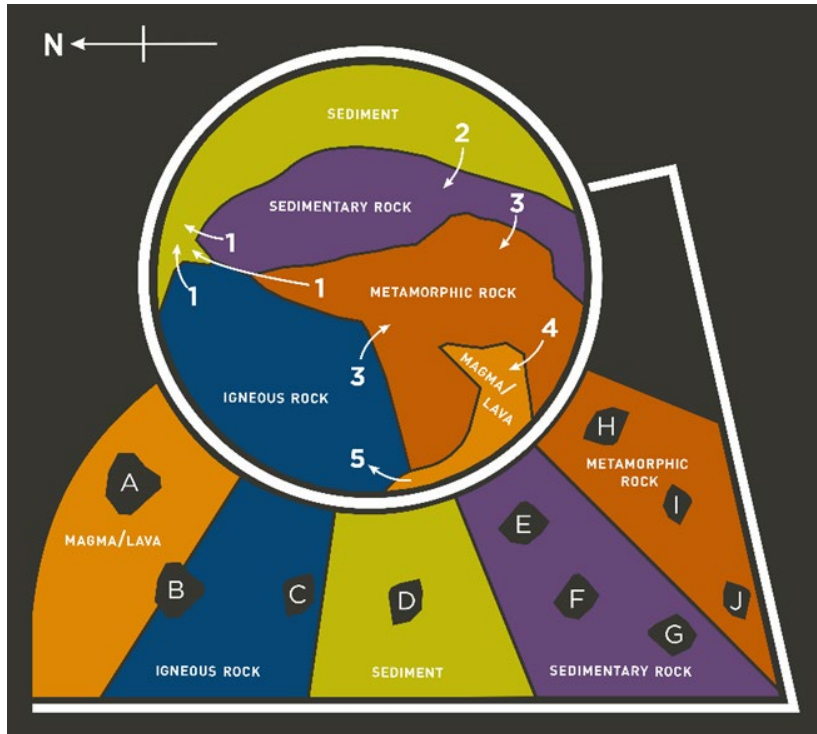

Figure 5. Enlargement of the inset map in Figure 4 of the Outdoor Geology Classroom display as featured on the signage at the site. The Rock Cycle circle is 20 meters in diameter. The lettered areas are real rock boulders and numbered arrows are Rock Cycle processes, all as explained on the sign (Figure 4). Processes operate in the direction of their arrows: (1) is weathering and erosion, (2) is lithification, (3) is metamorphism, (4) is melting, and (5) is crystallization. This representation of the Rock Cycle is more abstract than images of the Rock Cycle found in geology texts (cf. Figure 3) because the display is meant to be interactive, and this version makes more user-friendly sense. This design is more construction-friendly as well, and permitted the use of pavers and other construction materials to fill the area of the circle completely where fields are in contact with each other (cf. Figure 3).

Uses of the Outdoor Geology Classroom

The layout of the Outdoor Geology Classroom enables the space to be an outdoor teaching space (See Appendix A) and there is the explanatory signage (See Figure 4 above) to illustrate what a visitor is able to see there, and including information about how Plate Tectonics is the driving force. There is website support for this display and the “rock arboretum” (See the

website <https://earthsciences.buffalostate.edu/>). The outdoor display is interactive; anyone can walk through the Rock Cycle as if they were the Earth materials following the processes driven by tectonic plate motions.

Uses for College Courses

One of the primary goals of creating this space is for our introductory classes to be used when learning Earth materials including minerals, rocks, the Rock Cycle itself, and Rock Cycle processes. Tectonics is an important topic to be learned using the display. These topics are about 40% of our introductory geology course. The pavers used to represent the five components are actually those components (with the exception of magma/lava), and are arranged in roughly cycle order. The signage (Figure 4) is the explanation of the process connections. The larger rocks included in the display (the boulders, depicted as lettered fields in Figure 5, and seen in the photos in Appendix A) are some examples of rocks of each category. Students can examine those rocks and the pavers as just rocks (as one may do with the “rock arboretum”), and as part of the Rock Cycle, and physically move through the processes. As an additional benefit of having the Outdoor Geology Classroom, our graduate student teacher education candidates will use the space in their teaching preparation.

Uses by the Public

The display is outdoors on our open campus, so it is available for visiting at any time of day (or night). School class visits can occur at any time, on any day of the week, and mostly without prior arrangement. Larger groups are advised to check first with the Department of Earth Sciences and Science Education, or me, just to be sure, particularly during regular business hours. The Whitworth Ferguson Planetarium is adjacent, so planetarium show groups will invariably visit the outdoor classroom during their time on campus.

Timeline of the Creation of the Buffalo State College Outdoor Geology Classroom

At Buffalo State we have completed (2020) a 14-year combined new construction and renovation of our integrated natural science facilities known as the Science and Mathematics Complex. Ground was broken in 2006, and a new laboratory wing opened in January, 2013. The second phase (renovation) was completed in 2017. The addition of the extension to the

laboratory wing featuring the new Whitworth Ferguson Planetarium marked the completion of the work in summer 2020. At that time the outdoor displays were completed, whose centerpiece is what is known to the construction crew as the “Geology Garden” that includes a semi-circular seating wall to function as an occasional outdoor instructional area. Materials used include construction materials and rock boulders from across the country. Adjacent to the Outdoor Geology Classroom detailed herein, there is a scaled-down glacial feature garden, featuring an N-S-oriented drumlin field.

Details of the Buffalo State College Outdoor Geology Classroom – The Rock Cycle and Plate Tectonics

The Outdoor Geology Classroom is based on one of the two fundamental concepts in Earth Science – The Rock Cycle – the structural model that illustrates the dynamic and connected nature of minerals, sediment, rocks and magma/lava over time as driven by the other fundamental concept – Plate Tectonics. [See any introductory geology textbook for details on both the Rock Cycle and Plate Tectonics, or visit the United States Geological Survey web pages (see reference list)]. When within the display area, the materials under foot and around are arranged in process order.

Arrows on the signage at the display represent the 5 Rock Cycle processes that connect the 5 Rock Cycle components of magma/lava, igneous rock, sediment, sedimentary rock, and metamorphic rock in multiple cyclic paths. Following the numbering on Figures 3, 4, and 5, these Rock Cycle processes are (1) weathering and erosion, (2) lithification, (3) metamorphism, (4) melting, and (5) crystallization. An examination of Figure 5 and a walk through the display itself reveals that weathering and erosion (#1), and metamorphism (#3) connect several components in more than one path. The other processes are one way only between just two components. Sedimentary rocks are the only product of lithification (#2) of sediment. The process of melting (#4) to form magma/lava is exclusive in metamorphic rocks because only metamorphic rocks get hot enough in the rock cycle to melt. Metamorphic rocks are the only rocks to be buried deep enough. [Melting of rocks can otherwise occur as a result of meteor impacts, but impacts from space rocks are not part of the Rock Cycle.] After melting has produced magma/lava, only igneous rocks are formed from crystallization (#5) of the magma/lava. As previously stated, the signage at the Outdoor Geology Classroom features an

explanation of these processes. A visitor will be able to follow the cycle paths physically as they imagine the processes in operation (See Appendix A).

The Materials Used in the Display to Illustrate the Rock Cycle

As designed, the Rock Cycle is displayed using building materials to represent the solid (concrete and pavers) and magma/lava (acid-stained concrete) components. Real rock boulders are included in the outer arc to illustrate the various ways some of these components appear and may be related to each other by the Rock Cycle. The same materials used for each of the 5 Rock Cycle components (sediment, magma/lava, sedimentary rock, metamorphic rock, and igneous rock) are used both inside the circular area, and in the outer arc in order to show connectedness. The choice of building materials was a challenge because it is impossible to represent every variation of the Rock Cycle components with a reasonable amount of objects, so some concessions had to be made.

Exposed aggregate concrete is used to represent sediment. This is a good choice because the aggregate is real sedimentary material reduced from other rocks, and the texture of this kind of concrete is very much like that of some sedimentary piles. Magma/lava is represented by acid-stained concrete. (Try as I may, I could not get approved an actual lava flow for the display, so modified concrete was the compromise.) Pavers of sedimentary, metamorphic, and igneous rocks are used for their corresponding three rock components. Limestone pavers are used for sedimentary rocks, and slate is used for metamorphic rocks. Choosing a paver material for igneous rocks proved a challenge simply because there are no readily available pavers produced from straightforward igneous rocks. As a solution, we chose pavers of a rock called “migmatite” which is dominantly a metamorphic rock, but that has partially melted, and the melted product is frozen within it. The frozen melted product in our pavers is granite (light-colored component of a relatively dark-colored rock paver; See Appendix A bottom right).

There are ten rock boulders placed in the outer arc so that they are sitting within their relevant Rock Cycle component, as represented by the pavers or concrete (Figures 5 and Appendix A). This proved simpler for the 3 rock components, so the igneous, sedimentary, and metamorphic rock fields of the outer arc feature rocks from those categories. Choosing boulders for sediment and magma/lava proved more challenging. [Again, the request for a real lava flow was denied by the construction team, but also a pile of loose gravel for sediment seemed

inappropriate, and short-lived.] I settled on the volcanic rock vesicular basalt for magma/lava because it was lava just prior to becoming the rock (such rock is loosely called “lava rock” by the landscape industry). Despite being an igneous rock, a boulder of granite is in the “sediment” area (boulder D, Figures 4 and 5) because many of the minerals in granite end up either as clastic pieces of sediment in terrigenous sedimentary piles (e.g., quartz), or their weathered equivalents do (feldspar weathers to clay minerals). The other boulders were chosen as the best available examples of the range of rock and mineral textural variations in each of the three main rock categories. The sedimentary rocks show cross-bedding in both sandstone (boulder E) and dolostone (boulder G). The metamorphic rocks are mostly schistose gneisses, and show a variety of minerals found in most metamorphic rocks including garnet, sillimanite, and the micas that define the main mineral textures. Boulder H is a breccia after faulting – another connection with tectonics.

Conclusion

The Outdoor Geology Classroom at the Science and Mathematics Complex on the campus of Buffalo State College provides opportunities for every level of undergraduate and secondary geoscience education. The display is interactive and designed as an Earth materials exhibit, using rock and construction materials to represent components of the Rock Cycle that are driven by Plate Tectonics. At the same time, the Outdoor Geology Classroom is a geological process demonstration because the components are arranged in process relationships, illustrated by explanatory signage and website support. Visitors can walk through the display as if they are Earth materials cycling through the natural system, one that is tectonics driven. The display is accessible at all times of day. Provided there is not much snow cover, one can interact with the display on their own, or as part of a group formally or informally. The learning that is facilitated helps geology professors, primary and secondary school teachers, teacher candidates, and the public understand much of the Earth system.

About the Author

Dr. Gary Solar is an Associate Professor of Geology in the Department of Earth Sciences, SUNY Buffalo State in Buffalo, New York. He can be contacted via email at solargs@buffalostate.edu or through the department website at <https://earthsciences.buffalostate.edu/>.

References

- Kinmartin, M. (2006). The building stones and decorative rocks of the Buffalo State College campus: An outdoor rocks and minerals laboratory. *8th annual Student Research and Creativity Celebration*, Buffalo State College, Buffalo, NY.
- New York State Education Department. (2016). *New York State P-12 Science Learning Standards*. Retrieved from <http://www.nysed.gov/common/nysed/files/programs/curriculum-instruction/p-12-science-learning-standardsupdated10-18.pdf>
- United States Geological Survey (USGS, n.d.). Plate tectonics. Retrieved from <https://earthquake.usgs.gov/learn/glossary/?term=plate%20tectonics>
- United States Geological Survey (USGS, n.d.). The rock cycle. Retrieved from <https://archive.usgs.gov/archive/sites/www.usgs.gov/science/instance.php-term=8.html>

Appendix A. The Rock Cycle Outdoor Geology Classroom (under construction, March, 2020), looking south. Refer to the map in Figure 5, but note the perspective is looking left to right on that map. Each Rock Cycle component is represented by different pavers or concrete (as described in Figure 4). The lower-right photograph is a detail of the “igneous rock” pavers seen at right in the lower-left photograph. The pavers are migmatite (“mixed” rocks) of metamorphic rock (dark colors) hosting igneous rock (granite – light colors). The wall is for student seating during demonstrations and lecturing about the cycle. Find high-resolution images at the Outdoor Geology Classroom web page at <https://earthsciences.buffalostate.edu/>.

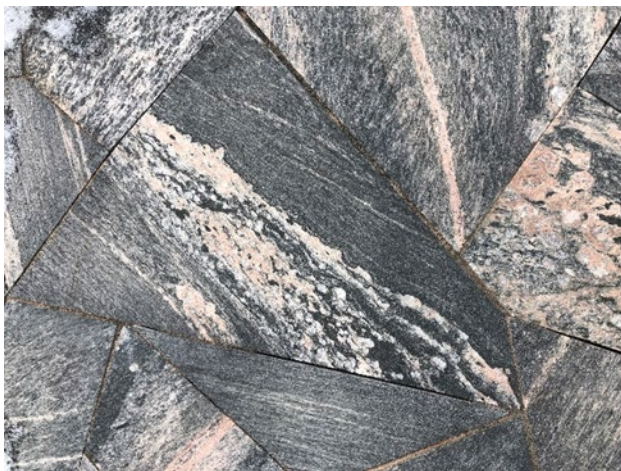

Submission Guidelines

<https://stanys.org/Science-Teachers-Bulletin>

The Science Teachers Bulletin welcomes articles about science and science education. If you wish to submit an article for publication, please prepare the following:

1. Double-spaced manuscript, 12-point font, and one-inch margins (in Microsoft Word format) with figures, tables, photos, or other images separated from the main body of text. Permission for image/photos use may be required.
2. Choose one of the following manuscript types for submission:
 - Feature Article: The main body of your manuscript should be approximately 2,000 words. References, captions, and other supplementary text are not included in the word count. A 200-word abstract should accompany submission of a Feature Article.
 - Innovation in Science Teaching Column: Share your how-to instructional strategies, practical advice, and classroom applicable results of action research. The column should be approximately 750-1000 words.
3. We strongly encourage you to demonstrate how your manuscript aligns with the *NYS Science Learning Standards* (2016) and the vision of *A Framework for K-12 Science Education* (See National Research Council, 2012).
4. References (if used) should appear at the end of the text using APA reference format.
5. An autobiographical sketch including your background, email, telephone number, and address should also be included.

For additional information or if you have any questions, please contact:

Aaron D. Isabelle, Ph.D.

***The Science Teachers Bulletin*, Editor**

State University of New York at New Paltz

800 Hawk Drive

New Paltz, NY 12561

Email: bulletineditor@stanys.org, isabella@newpaltz.edu

The Science Teachers Bulletin is published twice a year. Submitted manuscripts should not have been previously published or under consideration for publication elsewhere.

Opinions expressed in *The Science Teachers Bulletin* are those of the authors and do not necessarily reflect STANYS policy.

